

- # LEGEND:
- ipb O INTERNAL DOWN PIPE
 - EXISTING EXTERNAL WALL
 - EXISTING INTERNAL WALL
 - EXIT SIGN TO AS PER BCA REQUIREMENTS
 - METER BOX
 - HOT WATER SERVICES
 - (hw)

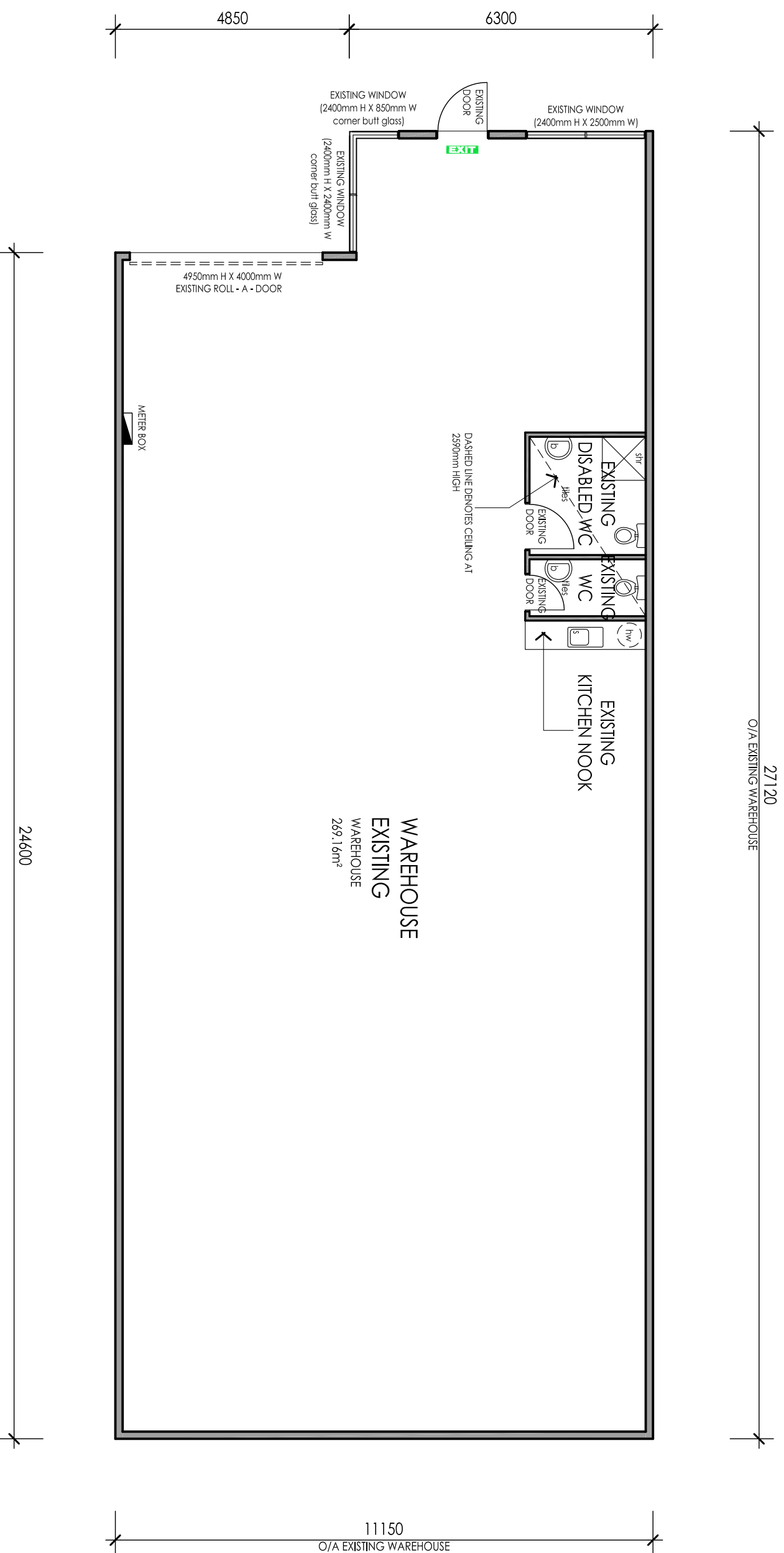

EXISTING FLOOR PLAN

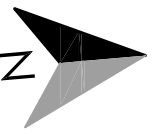

REVISION :	DRAWN :	J8
30/09/14 - CLIENT SKETCH 1	SCALE :	1:100 (A3)
06/10/14 - BUILDING PERMIT APPROVAL	PAGE :	03/05
13/10/14 - BUILDING PERMIT APPROVAL		



OFFICE B, 323 - 325 PASCOE VALE ROAD,
ESSENDON, VIC. 3040
 tel.: 9008 0253 fax: 9374 2444
 www.ultimateesign.com.au
 registration no.: DP - AD 22883

PROJECT :	PROPOSED NEW FACTORY FIT OUT
ADDRESS :	(DOUBLE STOREY) NO.27 FACTORY 31, EUCLUMBERNE DRIVE, RAVENHILL
CLIENT :	CPT ELECTRICAL
DWG TITLE :	WORKING DRAWINGS

JOB No:
D - 4500

LEGEND:

- ↳ INTERNAL DOWN PIPE
- ▬ EXISTING EXTERNAL WALL
- ▬ EXISTING INTERNAL WALL
- ▬ PROPOSED INTERNAL WALL
- EXIT SIGN TO AS PER BCA REQUIREMENTS
- METER BOX
- HOT WATER SERVICES

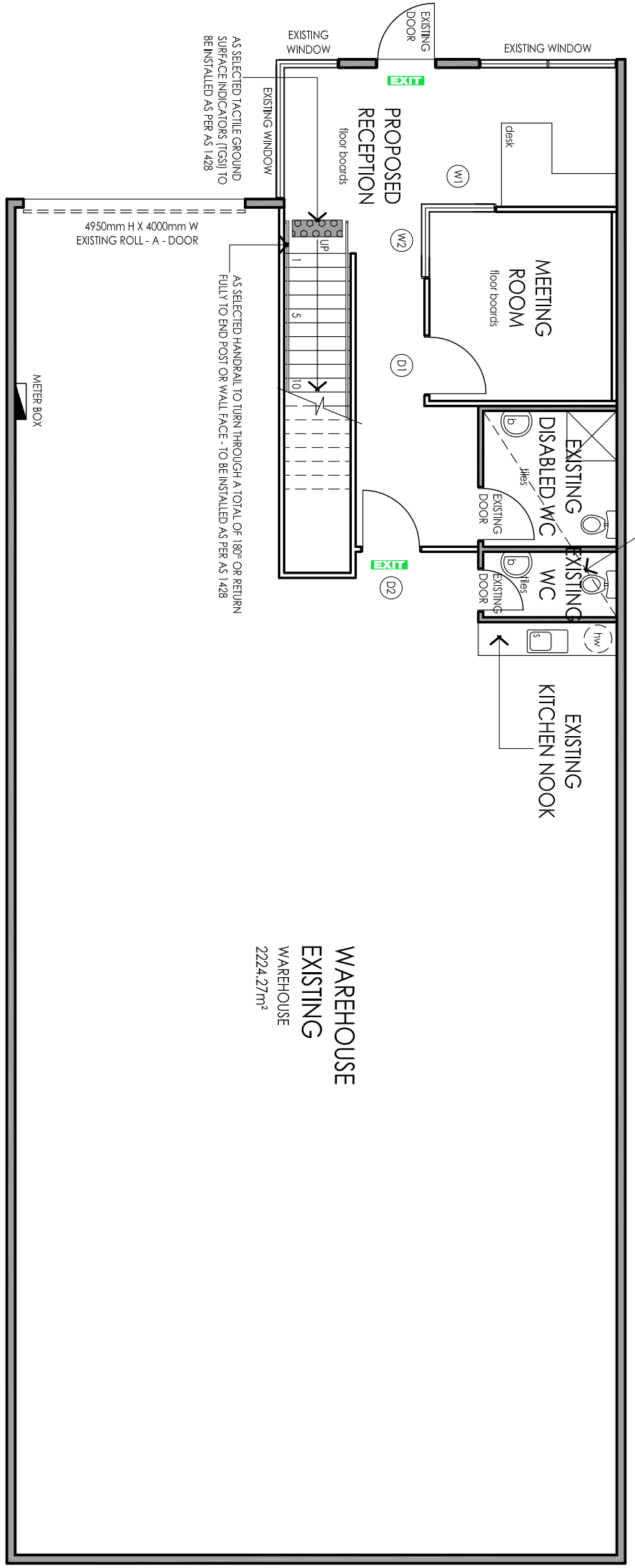
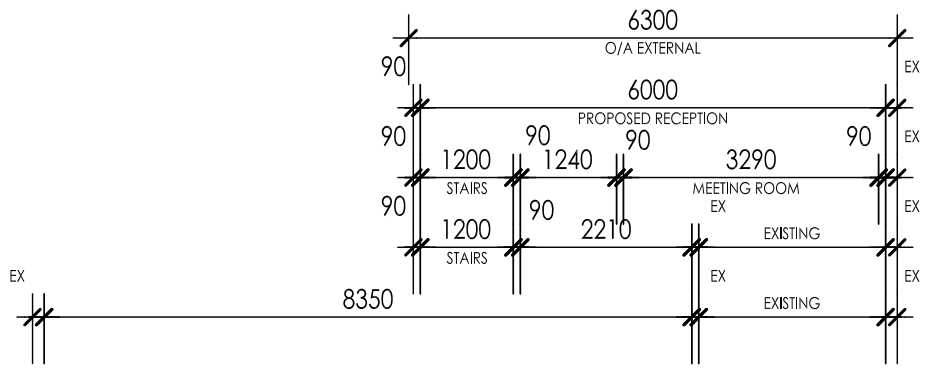
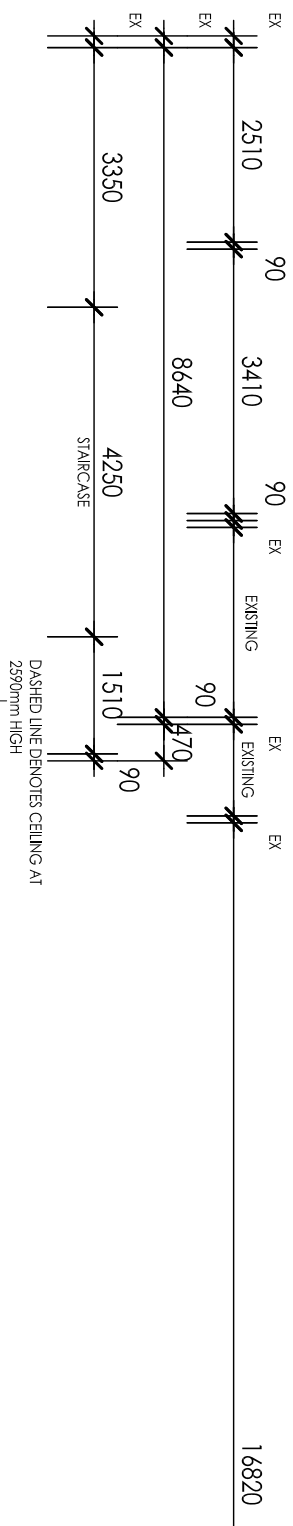

PROPOSED GROUND FLOOR GENERAL NOTES

ALL DIMENSIONS AND LEVELS SHOULD BE CHECKED AND VERIFIED ON SITE PRIOR TO THE COMMENCEMENT OF ANY CONSTRUCTION AND/OR FABRICATION. IT IS THE BUILDERS AND/OR CONTRACTORS RESPONSIBILITY TO ENSURE THE SAME.

F.I.L MUST BE APPROVED BY BUILDER BEFORE ANY GROUND WORK IS STARTED. THE F.I.L IS INDICATIVE ONLY AND MUST BE BE CONFIRMED

METER BOX, GAS METER AND HOT WATER UNIT LOCATION ARE INDICATIVE ONLY AND SHOULD BE CONFIRMED WITH AN AUTHORIZED PERSON AND BUILDER FOR LOCATION.

IN THE INTEREST OF GOOD BUILDING PRACTICE, THE BUILDER MAY AT HIS DISCRETION CONSTRUCT DUCTS, BULKHEADS, VOIDS AND THE LIKE TO CONCEAL PLUMBING, DUCTWORK ETC.

GROUND FLOOR WINDOW / DOOR SCHEDULE		
WINDOW No	WINDOW LOCATION	WINDOW TYPE
W1	MEETING ROOM	FIXED
W2	MEETING ROOM	FIXED
D1	MEETING ROOM	SOLID DOOR
D2	WAREHOUSE	SOLID DOOR

REVISION :	DRAWN :	J8
30/09/14 - CLIENT SKETCH 1	SCALE :	1:100 (A3)
06/10/14 - BUILDING PERMIT APPROVAL	PAGE :	04/05
13/10/14 - BUILDING PERMIT APPROVAL		

OFFICE B, 323 - 325 PASCOE VALE ROAD, ESSENDON, VIC, 3040
 tel: 9008 0253 fax: 9374 2444
 www.ultimatedesign.com.au
 registration no: DP4 - AD 22833

PROJECT : PROPOSED NEW FACTORY FIT OUT (DOUBLE STOREY)
 ADDRESS : No 27 FACTORY 31, EUCUMBERNE DRIVE, RAVENHILL
 CLIENT : CPT ELECTRICAL
 DWG TITLE : WORKING DRAWINGS

JOB No: **D - 4500**

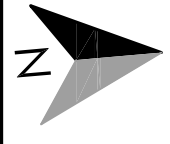

LEGEND:

- ↳ INTERNAL DOWN PIPE
- ↳ EXISTING EXTERNAL WALL
- ↳ PROPOSED INTERNAL WALL

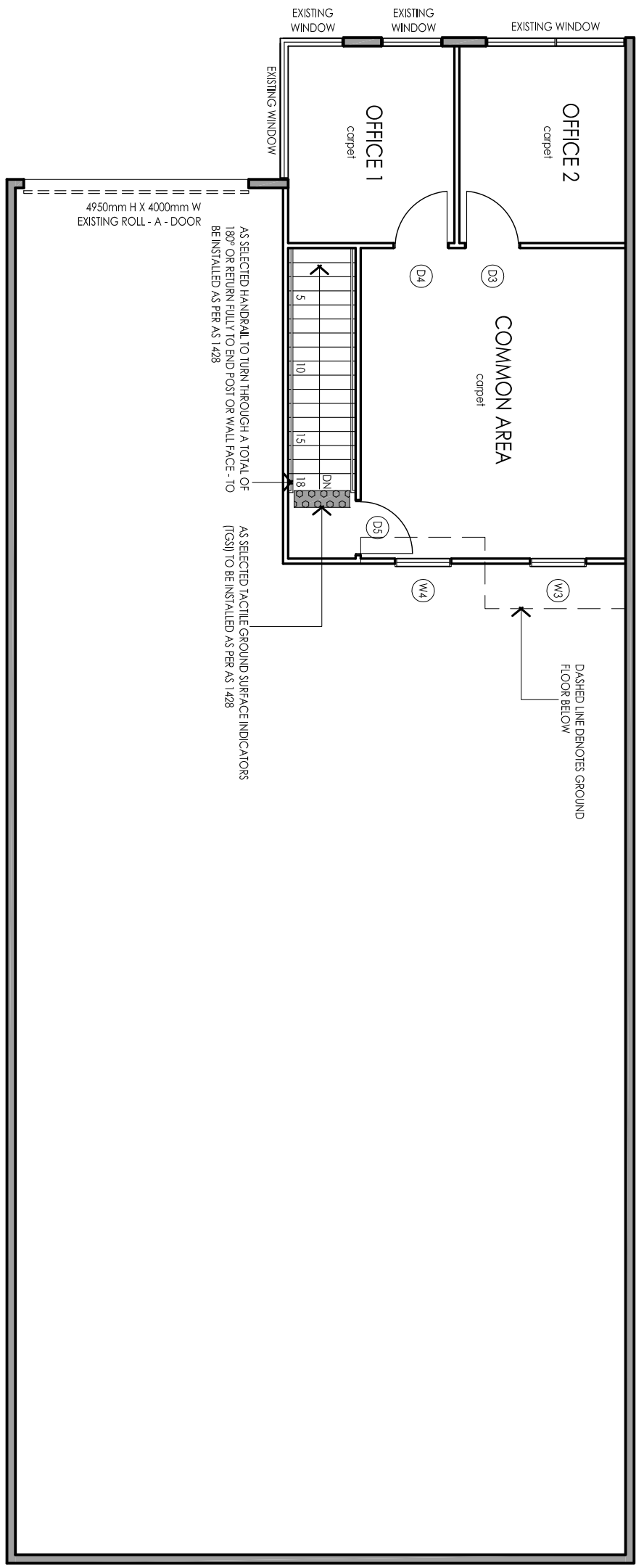
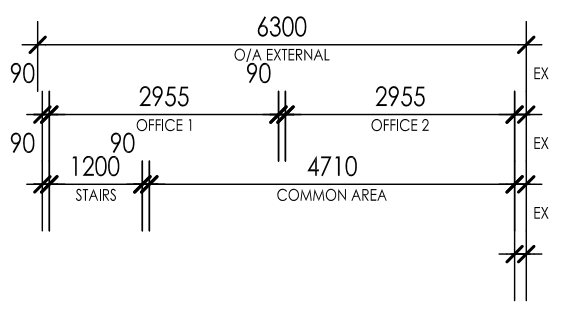
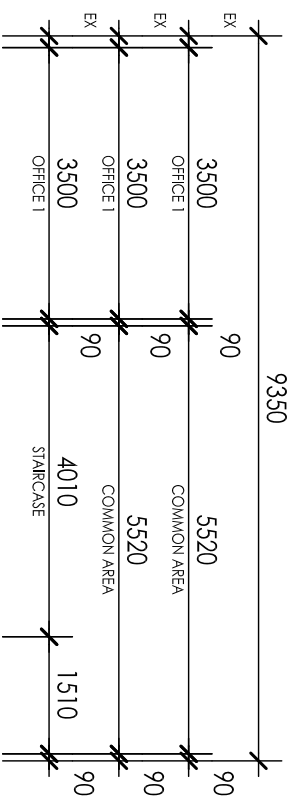

PROPOSED MEZZANINE FLOOR PLAN

ALL DIMENSIONS AND LEVELS SHOULD BE CHECKED AND VERIFIED ON SITE PRIOR TO THE COMMENCEMENT OF ANY CONSTRUCTION AND/OR FABRICATION. IT IS THE BUILDERS AND/OR CONTRACTORS RESPONSIBILITY TO ENSURE THE SAME.

F.F.L MUST BE APPROVED BY BUILDER BEFORE ANY GROUND WORK IS STARTED. THE F.F.L IS INDICATIVE ONLY AND MUST BE BE CONFIRMED

METER BOX, GAS METER AND HOT WATER UNIT LOCATION ARE INDICATIVE ONLY AND SHOULD BE CONFIRMED WITH AN AUTHORIZED PERSON AND BUILDER FOR LOCATION.

IN THE INTEREST OF GOOD BUILDING PRACTICE, THE BUILDER MAY AT HIS DISCRETION CONSTRUCT DUCTS, BULKHEADS, VOIDS AND THE LIKE TO CONCEAL PLUMBING, DUCTWORK ETC.

MEZZANINE FLOOR WINDOW / DOOR SCHEDULE			
WINDOW No	WINDOW LOCATION	WINDOW SIZE	WINDOW TYPE
W3	COMMON AREA	1400mm H X 1000mm W	FIXED
W4	COMMON AREA	1400mm H X 1000mm W	FIXED
D3	OFFICE 2	2340mm H X 920mm W	SOLID DOOR
D4	OFFICE 1	2340mm H X 920mm W	SOLID DOOR
D5	STAIRCASE	2340mm H X 920mm W	SOLID DOOR

REVISION :	DRAWN :	J8
30/09/14 - CLIENT SKETCH 1	SCALE :	1:100 (A3)
06/10/14 - BUILDING PERMIT APPROVAL	PAGE :	05/05
13/10/14 - BUILDING PERMIT APPROVAL		
		13/10/2014

ultimate
design and drafters Pty. Ltd
OFFICE B, 323 - 325 PASCOE VALE ROAD,
ESSENDON, VIC. 3040
tel: 9008 0253 fax: 9374 2444
www.ultimedesign.com.au
registration no: DP-AD-22833

PROJECT : PROPOSED NEW FACTORY FIT OUT (DOUBLE STOREY)
ADDRESS : No 27 FACTORY 31, EUCUMBERNE DRIVE, RAVENHILL
CLIENT : CPT ELECTRICAL
DWG TITLE : WORKING DRAWINGS

JOB No: **D - 4500**

