

Contract for the sale and purchase of land 2019 edition

TERM	MEANING OF TERM	eCOS ID: 68973795	NSW DAN:
vendor's agent	Upstate Suite 15, Leevl 1, 888 Pittwater Road, Dee Why NSW 2099		Phone: 0405157059 Fax: Ref: Martin Orth
co-agent			
vendor	MITSUYOSHI HABADERA		
vendor's solicitor	Concibus Legal Pty Ltd 201 46 Market Street Sydney NSW 2000		Phone: 02 8002 1281 Fax: 9281 5548 Ref: Yoshi
date for completion	42 days after the contract date	(clause 15)	Email: admin@concibus.com.au
land	17/11-13 HOLBORN AVE DEE WHY NSW 2099 (Address, plan details and title reference) LOT 17 IN STRATA PLAN 80483 17/SP80483		
	<input type="checkbox"/> VACANT POSSESSION <input type="checkbox"/> Subject to existing tenancies		
improvements	<input type="checkbox"/> HOUSE <input type="checkbox"/> garage <input type="checkbox"/> carport <input type="checkbox"/> home unit <input type="checkbox"/> carspace <input type="checkbox"/> storage space <input type="checkbox"/> none <input type="checkbox"/> other:		
attached copies	<input type="checkbox"/> documents in the List of Documents as marked or as numbered: <input type="checkbox"/> other documents:		

A real estate agent is permitted by legislation to fill up the items in this box in a sale of residential property.

inclusions	<input type="checkbox"/> blinds	<input type="checkbox"/> dishwasher	<input type="checkbox"/> light fittings	<input type="checkbox"/> stove
	<input type="checkbox"/> built-in wardrobes	<input type="checkbox"/> fixed floor coverings	<input type="checkbox"/> range hood	<input type="checkbox"/> pool equipment
	<input type="checkbox"/> clothes line	<input type="checkbox"/> insect screens	<input type="checkbox"/> solar panels	<input type="checkbox"/> TV antenna
	<input type="checkbox"/> curtains	<input type="checkbox"/> other:		
exclusions				
purchaser				
purchaser's solicitor			Phone:	
			Fax:	
			Ref:	
price	\$		Email:	
deposit	\$		(10% of the price, unless otherwise stated)	
balance	\$			
contract date			(if not stated, the date this contract was made)	

buyer's agent

vendor

witness

GST AMOUNT (optional)

The price includes

GST of: \$

purchaser

JOINT TENANTS

tenants in common

in unequal shares

witness

BREACH OF COPYRIGHT MAY RESULT IN LEGAL ACTION

Yoshi

68973795

vendor agrees to accept a **deposit-bond** (clause 3) NO yes

Nominated Electronic Lodgment Network (ELN) (clause 30)

Electronic transaction (clause 30) no YES

(if no, vendor must provide further details, such as the proposed applicable waiver, in the space below, or *serve within 14 days* of the contract date):

Tax information (the parties promise this is correct as far as each party is aware)

land tax is adjustable NO yes

GST: Taxable supply NO yes in full yes to an extent

Margin scheme will be used in making the taxable supply NO yes

This sale is not a taxable supply because (one or more of the following may apply) the sale is:

- not made in the course or furtherance of an enterprise that the vendor carries on (section 9-5(b))
- by a vendor who is neither registered nor required to be registered for GST (section 9-5(d))
- GST-free because the sale is the supply of a going concern under section 38-325
- GST-free because the sale is subdivided farm land or farm land supplied for farming under Subdivision 38-O
- input taxed because the sale is of eligible residential premises (sections 40-65, 40-75(2) and 195-1)

Purchaser must make an *GSTRW payment* (residential withholding payment) NO yes(if yes, vendor must provide further details)

If the further details below are not fully completed at the contract date, the vendor must provide all these details in a separate notice *within 14 days* of the contract date.

GSTRW payment (GST residential withholding payment) – further details

Frequently the supplier will be the vendor. However, sometimes further information will be required as to which entity is liable for GST, for example, if the supplier is a partnership, a trust, part of a GST group or a participant in a GST joint venture.

Supplier’s name:

Supplier’s ABN:

Supplier’s GST branch number (if applicable):

Supplier’s business address:

Supplier’s email address:

Supplier’s phone number:

Supplier’s proportion of *GSTRW payment*: \$

If more than one supplier, provide the above details for each supplier.

Amount purchaser must pay – price multiplied by the *RW rate* (residential withholding rate): \$

Amount must be paid: AT COMPLETION at another time (specify):

Is any of the consideration not expressed as an amount in money? NO yes

If “yes”, the GST inclusive market value of the non-monetary consideration: \$

Other details (including those required by regulation or the ATO forms):

List of Documents

General	Strata or community title (clause 23 of the contract)
<input checked="" type="checkbox"/> 1 property certificate for the land	<input checked="" type="checkbox"/> 32 property certificate for strata common property
<input checked="" type="checkbox"/> 2 plan of the land	<input checked="" type="checkbox"/> 33 plan creating strata common property
<input type="checkbox"/> 3 unregistered plan of the land	<input type="checkbox"/> 34 strata by-laws
<input type="checkbox"/> 4 plan of land to be subdivided	<input type="checkbox"/> 35 strata development contract or statement
<input type="checkbox"/> 5 document that is to be lodged with a relevant plan	<input type="checkbox"/> 36 strata management statement
<input type="checkbox"/> 6 section 10.7(2) planning certificate under Environmental Planning and Assessment Act 1979	<input type="checkbox"/> 37 strata renewal proposal
<input type="checkbox"/> 7 additional information included in that certificate under section 10.7(5)	<input type="checkbox"/> 38 strata renewal plan
<input checked="" type="checkbox"/> 8 sewerage infrastructure location diagram (service location diagram)	<input type="checkbox"/> 39 leasehold strata - lease of lot and common property
<input checked="" type="checkbox"/> 9 sewer lines location diagram (sewerage service diagram)	<input type="checkbox"/> 40 property certificate for neighbourhood property
<input type="checkbox"/> 10 document that created or may have created an easement, profit à prendre, restriction on use or positive covenant disclosed in this contract	<input type="checkbox"/> 41 plan creating neighbourhood property
<input type="checkbox"/> 11 <i>planning agreement</i>	<input type="checkbox"/> 42 neighbourhood development contract
<input type="checkbox"/> 12 section 88G certificate (positive covenant)	<input type="checkbox"/> 43 neighbourhood management statement
<input type="checkbox"/> 13 survey report	<input type="checkbox"/> 44 property certificate for precinct property
<input type="checkbox"/> 14 building information certificate or building certificate given under <i>legislation</i>	<input type="checkbox"/> 45 plan creating precinct property
<input type="checkbox"/> 15 lease (with every relevant memorandum or variation)	<input type="checkbox"/> 46 precinct development contract
<input type="checkbox"/> 16 other document relevant to tenancies	<input type="checkbox"/> 47 precinct management statement
<input type="checkbox"/> 17 licence benefiting the land	<input type="checkbox"/> 48 property certificate for community property
<input type="checkbox"/> 18 old system document	<input type="checkbox"/> 49 plan creating community property
<input type="checkbox"/> 19 Crown purchase statement of account	<input type="checkbox"/> 50 community development contract
<input type="checkbox"/> 20 building management statement	<input type="checkbox"/> 51 community management statement
<input type="checkbox"/> 21 form of requisitions	<input type="checkbox"/> 52 document disclosing a change of by-laws
<input checked="" type="checkbox"/> 22 <i>clearance certificate</i>	<input type="checkbox"/> 53 document disclosing a change in a development or management contract or statement
<input checked="" type="checkbox"/> 23 land tax certificate	<input type="checkbox"/> 54 document disclosing a change in boundaries
Home Building Act 1989	<input type="checkbox"/> 55 information certificate under Strata Schemes Management Act 2015
<input type="checkbox"/> 24 insurance certificate	<input type="checkbox"/> 56 information certificate under Community Land Management Act 1989
<input type="checkbox"/> 25 brochure or warning	<input type="checkbox"/> 57 disclosure statement - off the plan contract
<input type="checkbox"/> 26 evidence of alternative indemnity cover	<input type="checkbox"/> 58 other document relevant to off the plan contract
Swimming Pools Act 1992	Other
<input type="checkbox"/> 27 certificate of compliance	<input type="checkbox"/> 59
<input type="checkbox"/> 28 evidence of registration	
<input type="checkbox"/> 29 relevant occupation certificate	
<input type="checkbox"/> 30 certificate of non-compliance	
<input type="checkbox"/> 31 detailed reasons of non-compliance	

HOLDER OF STRATA OR COMMUNITY TITLE RECORDS – Name, address, email address and telephone number

Lamb & Walters
19-23 Bridge St, Pymble

94498855
tim@lambandwalters.com.au

IMPORTANT NOTICE TO VENDORS AND PURCHASERS

Before signing this contract you should ensure that you understand your rights and obligations, some of which are not written in this contract but are implied by law.

WARNING—SMOKE ALARMS

The owners of certain types of buildings and strata lots must have smoke alarms (or in certain cases heat alarms) installed in the building or lot in accordance with regulations under the *Environmental Planning and Assessment Act 1979*. It is an offence not to comply. It is also an offence to remove or interfere with a smoke alarm or heat alarm. Penalties apply.

WARNING—LOOSE-FILL ASBESTOS INSULATION

Before purchasing land that includes any residential premises (within the meaning of Division 1A of Part 8 of the *Home Building Act 1989*) built before 1985, a purchaser is strongly advised to consider the possibility that the premises may contain loose-fill asbestos insulation (within the meaning of Division 1A of Part 8 of the *Home Building Act 1989*). In particular, a purchaser should:

- (a) search the Register required to be maintained under Division 1A of Part 8 of the *Home Building Act 1989*, and
- (b) ask the relevant local council whether it holds any records showing that the residential premises contain loose-fill asbestos insulation.

For further information about loose-fill asbestos insulation (including areas in which residential premises have been identified as containing loose-fill asbestos insulation), contact NSW Fair Trading.

COOLING OFF PERIOD (PURCHASER'S RIGHTS)

1. This is the statement required by section 66X of the *Conveyancing Act 1919* and applies to a contract for the sale of residential property.
2. **EXCEPT** in the circumstances listed in paragraph 3, the purchaser may rescind the contract at any time before 5 pm on—
 - (a) the tenth business day after the day on which the contract was made—in the case of an off the plan contract, or
 - (b) the fifth business day after the day on which the contract was made—in any other case.
3. There is **NO COOLING OFF PERIOD**:
 - (a) if, at or before the time the contract is made, the purchaser gives to the vendor (or the vendor's solicitor or agent) a certificate that complies with section 66W of the Act, or
 - (b) if the property is sold by public auction, or
 - (c) if the contract is made on the same day as the property was offered for sale by public auction but passed in, or
 - (d) if the contract is made in consequence of the exercise of an option to purchase the property, other than an option that is void under section 66ZG of the Act.
4. A purchaser exercising the right to cool off by rescinding the contract will forfeit to the vendor 0.25% of the purchase price of the property. The vendor is entitled to recover the amount forfeited from any amount paid by the purchaser as a deposit under the contract and the purchaser is entitled to a refund of any balance.

DISPUTES

If you get into a dispute with the other party, the Law Society and Real Estate Institute encourage you to use informal procedures such as negotiation, independent expert appraisal, the Law Society Conveyancing Dispute Resolution Scheme or mediation (for example mediation under the Law Society Mediation Program).

AUCTIONS

Regulations made under the Property, Stock and Business Agents Act 2002 prescribe a number of conditions applying to sales by auction.

WARNINGS

1. Various Acts of Parliament and other matters can affect the rights of the parties to this contract. Some important matters are actions, claims, decisions, licences, notices, orders, proposals or rights of way involving:

APA Group Australian Taxation Office Council County Council Department of Planning, Industry and Environment Department of Primary Industries Electricity and gas Land & Housing Corporation Local Land Services	NSW Department of Education NSW Fair Trading Owner of adjoining land Privacy Public Works Advisory Subsidence Advisory NSW Telecommunications Transport for NSW Water, sewerage or drainage authority
---	--

If you think that any of these matters affects the property, tell your solicitor.
2. A lease may be affected by the Agricultural Tenancies Act 1990, the Residential Tenancies Act 2010 or the Retail Leases Act 1994.
3. If any purchase money is owing to the Crown, it will become payable before obtaining consent, or if no consent is needed, when the transfer is registered.
4. If a consent to transfer is required under legislation, see clause 27 as to the obligations of the parties.
5. The vendor should continue the vendor's insurance until completion. If the vendor wants to give the purchaser possession before completion, the vendor should first ask the insurer to confirm this will not affect the insurance.
6. The purchaser will usually have to pay transfer duty (and sometimes surcharge purchaser duty) on this contract. If duty is not paid on time, a purchaser may incur penalties.
7. If the purchaser agrees to the release of deposit, the purchaser's right to recover the deposit may stand behind the rights of others (for example the vendor's mortgagee).
8. The purchaser should arrange insurance as appropriate.
9. Some transactions involving personal property may be affected by the Personal Property Securities Act 2009.
10. A purchaser should be satisfied that finance will be available at the time of completing the purchase.
11. Where the market value of the property is at or above a legislated amount, the purchaser may have to comply with a foreign resident capital gains withholding payment obligation (even if the vendor is not a foreign resident). If so, this will affect the amount available to the vendor on completion.
12. Purchasers of some residential properties may have to withhold part of the purchase price to be credited towards the GST liability of the vendor. If so, this will also affect the amount available to the vendor. More information is available from the ATO.

The vendor sells and the purchaser buys the *property* for the price under these provisions instead of Schedule 3 Conveyancing Act 1919, subject to any *legislation* that cannot be excluded.

1 Definitions (a term in italics is a defined term)

In this contract, these terms (in any form) mean –

<i>adjustment date</i>	the earlier of the giving of possession to the purchaser or completion;
<i>bank</i>	the Reserve Bank of Australia or an authorised deposit-taking institution which is a bank, a building society or a credit union;
<i>business day</i>	any day except a bank or public holiday throughout NSW or a Saturday or Sunday;
<i>cheque</i>	a cheque that is not postdated or stale;
<i>clearance certificate</i>	a certificate within the meaning of s14-220 of Schedule 1 to the <i>TA Act</i> , that covers one or more days falling within the period from and including the contract date to completion;
<i>deposit-bond</i>	a deposit bond or guarantee from an issuer, with an expiry date and for an amount each approved by the vendor;
<i>depositholder</i>	vendor's agent (or if no vendor's agent is named in this contract, the vendor's <i>solicitor</i> , or if no vendor's <i>solicitor</i> is named in this contract, the buyer's agent);
<i>document of title</i>	document relevant to the title or the passing of title;
<i>FRCGW percentage</i>	the percentage mentioned in s14-200(3)(a) of Schedule 1 to the <i>TA Act</i> (12.5% as at 1 July 2017);
<i>FRCGW remittance</i>	a remittance which the purchaser must make under s14-200 of Schedule 1 to the <i>TA Act</i> , being the lesser of the <i>FRCGW percentage</i> of the price (inclusive of GST, if any) and the amount specified in a <i>variation served by a party</i> ;
<i>GST Act</i>	A New Tax System (Goods and Services Tax) Act 1999;
<i>GST rate</i>	the rate mentioned in s4 of A New Tax System (Goods and Services Tax Imposition - General) Act 1999 (10% as at 1 July 2000);
<i>GSTRW payment</i>	a payment which the purchaser must make under s14-250 of Schedule 1 to the <i>TA Act</i> (the price multiplied by the <i>GSTRW rate</i>);
<i>GSTRW rate</i>	the rate determined under ss14-250(6), (8) or (9) of Schedule 1 to the <i>TA Act</i> (as at 1 July 2018, usually 7% of the price if the margin scheme applies, 1/11 th if not);
<i>legislation</i>	an Act or a by-law, ordinance, regulation or rule made under an Act;
<i>normally</i>	subject to any other provision of this contract;
<i>party</i>	each of the vendor and the purchaser;
<i>property</i>	the land, the improvements, all fixtures and the inclusions, but not the exclusions;
<i>planning agreement</i>	a valid voluntary agreement within the meaning of s7.4 of the Environmental Planning and Assessment Act 1979 entered into in relation to the <i>property</i> ;
<i>requisition</i>	an objection, question or requisition (but the term does not include a claim);
<i>rescind</i>	rescind this contract from the beginning;
<i>serve</i>	serve in writing on the other <i>party</i> ;
<i>settlement cheque</i>	an unendorsed <i>cheque</i> made payable to the person to be paid and – <ul style="list-style-type: none"> • issued by a <i>bank</i> and drawn on itself; or • if authorised in writing by the vendor or the vendor's <i>solicitor</i>, some other <i>cheque</i>;
<i>solicitor</i>	in relation to a <i>party</i> , the <i>party's</i> solicitor or licensed conveyancer named in this contract or in a notice <i>served by the party</i> ;
<i>TA Act</i>	Taxation Administration Act 1953;
<i>terminate</i>	terminate this contract for breach;
<i>variation</i>	a variation made under s14-235 of Schedule 1 to the <i>TA Act</i> ;
<i>within</i>	in relation to a period, at any time before or during the period; and
<i>work order</i>	a valid direction, notice or order that requires work to be done or money to be spent on or in relation to the <i>property</i> or any adjoining footpath or road (but the term does not include a notice under s22E of the Swimming Pools Act 1992 or clause 22 of the Swimming Pools Regulation 2018).

2 Deposit and other payments before completion

- 2.1 The purchaser must pay the deposit to the *depositholder* as stakeholder.
- 2.2 *Normally*, the purchaser must pay the deposit on the making of this contract, and this time is essential.
- 2.3 If this contract requires the purchaser to pay any of the deposit by a later time, that time is also essential.
- 2.4 The purchaser can pay any of the deposit by giving cash (up to \$2,000) or by unconditionally giving a *cheque* to the *depositholder* or to the vendor, vendor's agent or vendor's *solicitor* for sending to the *depositholder* or by payment by electronic funds transfer to the *depositholder*.
- 2.5 If any of the deposit is not paid on time or a *cheque* for any of the deposit is not honoured on presentation, the vendor can *terminate*. This right to *terminate* is lost as soon as the deposit is paid in full.
- 2.6 If the vendor accepts a bond or guarantee for the deposit, clauses 2.1 to 2.5 do not apply.

- 2.7 If the vendor accepts a bond or guarantee for part of the deposit, clauses 2.1 to 2.5 apply only to the balance.
- 2.8 If any of the deposit or of the balance of the price is paid before completion to the vendor or as the vendor directs, it is a charge on the land in favour of the purchaser until *termination* by the vendor or completion, subject to any existing right.
- 2.9 If each *party* tells the *depositholder* that the deposit is to be invested, the *depositholder* is to invest the deposit (at the risk of the *party* who becomes entitled to it) with a *bank*, in an interest-bearing account in NSW, payable at call, with interest to be reinvested, and pay the interest to the *parties* equally, after deduction of all proper government taxes and financial institution charges and other charges.

3 Deposit-bond

- 3.1 This clause applies only if this contract says the vendor has agreed to accept a *deposit-bond* for the deposit (or part of it).
- 3.2 The purchaser must provide the original *deposit-bond* to the vendor's *solicitor* (or if no *solicitor* the *depositholder*) at or before the making of this contract and this time is essential.
- 3.3 If the *deposit-bond* has an expiry date and completion does not occur by the date which is 14 days before the expiry date, the purchaser must *serve* a replacement *deposit-bond* at least 7 days before the expiry date. The time for service is essential.
- 3.4 The vendor must approve a replacement *deposit-bond* if –
- 3.4.1 it is from the same issuer and for the same amount as the earlier *deposit-bond*; and
- 3.4.2 it has an expiry date at least three months after its date of issue.
- 3.5 A breach of clauses 3.2 or 3.3 entitles the vendor to *terminate*. The right to *terminate* is lost as soon as –
- 3.5.1 the purchaser *serves* a replacement *deposit-bond*; or
- 3.5.2 the deposit is paid in full under clause 2.
- 3.6 Clauses 3.3 and 3.4 can operate more than once.
- 3.7 If the purchaser *serves* a replacement *deposit-bond*, the vendor must *serve* the earlier *deposit-bond*.
- 3.8 The amount of any *deposit-bond* does not form part of the price for the purposes of clause 16.7.
- 3.9 The vendor must give the purchaser the *deposit-bond* –
- 3.9.1 on completion; or
- 3.9.2 if this contract is *rescinded*.
- 3.10 If this contract is *terminated* by the vendor –
- 3.10.1 *normally*, the vendor can immediately demand payment from the issuer of the *deposit-bond*; or
- 3.10.2 if the purchaser *serves* prior to *termination* a notice disputing the vendor's right to *terminate*, the vendor must forward the *deposit-bond* (or its proceeds if called up) to the *depositholder* as stakeholder.
- 3.11 If this contract is *terminated* by the purchaser –
- 3.11.1 *normally*, the vendor must give the purchaser the *deposit-bond*; or
- 3.11.2 if the vendor *serves* prior to *termination* a notice disputing the purchaser's right to *terminate*, the vendor must forward the *deposit-bond* (or its proceeds if called up) to the *depositholder* as stakeholder.

4 Transfer

- 4.1 *Normally*, the purchaser must *serve* at least 14 days before the date for completion –
- 4.1.1 the form of transfer; and
- 4.1.2 particulars required to register any mortgage or other dealing to be lodged with the transfer by the purchaser or the purchaser's mortgagee.
- 4.2 If any information needed for the form of transfer is not disclosed in this contract, the vendor must *serve* it.
- 4.3 If the purchaser *serves* a form of transfer and the transferee is not the purchaser, the purchaser must give the vendor a direction signed by the purchaser personally for this form of transfer.
- 4.4 The vendor can require the purchaser to include a form of covenant or easement in the transfer only if this contract contains the wording of the proposed covenant or easement, and a description of the land benefited.

5 Requisitions

- 5.1 If a form of *requisitions* is attached to this contract, the purchaser is taken to have made those *requisitions*.
- 5.2 If the purchaser is or becomes entitled to make any other *requisition*, the purchaser can make it only by *serving* it –
- 5.2.1 if it arises out of this contract or it is a general question about the *property* or title - *within* 21 days after the contract date;
- 5.2.2 if it arises out of anything *served* by the vendor - *within* 21 days after the later of the contract date and that *service*; and
- 5.2.3 in any other case - *within* a reasonable time.

6 Error or misdescription

- 6.1 *Normally*, the purchaser can (but only before completion) claim compensation for an error or misdescription in this contract (as to the *property*, the title or anything else and whether substantial or not).
- 6.2 This clause applies even if the purchaser did not take notice of or rely on anything in this contract containing or giving rise to the error or misdescription.
- 6.3 However, this clause does not apply to the extent the purchaser knows the true position.

7 Claims by purchaser

Normally, the purchaser can make a claim (including a claim under clause 6) before completion only by *servicing* it with a statement of the amount claimed, and if the purchaser makes one or more claims before completion –

- 7.1 the vendor can *rescind* if in the case of claims that are not claims for delay –
- 7.1.1 the total amount claimed exceeds 5% of the price;
- 7.1.2 the vendor *serves* notice of intention to *rescind*; and
- 7.1.3 the purchaser does not *serve* notice waiving the claims *within* 14 days after that *service*; and
- 7.2 if the vendor does not *rescind*, the *parties* must complete and if this contract is completed –
- 7.2.1 the lesser of the total amount claimed and 10% of the price must be paid out of the price to and held by the *depositholder* until the claims are finalised or lapse;
- 7.2.2 the amount held is to be invested in accordance with clause 2.9;
- 7.2.3 the claims must be finalised by an arbitrator appointed by the *parties* or, if an appointment is not made *within* 1 month of completion, by an arbitrator appointed by the President of the Law Society at the request of a *party* (in the latter case the *parties* are bound by the terms of the Conveyancing Arbitration Rules approved by the Law Society as at the date of the appointment);
- 7.2.4 the purchaser is not entitled, in respect of the claims, to more than the total amount claimed and the costs of the purchaser;
- 7.2.5 net interest on the amount held must be paid to the *parties* in the same proportion as the amount held is paid; and
- 7.2.6 if the *parties* do not appoint an arbitrator and neither *party* requests the President to appoint an arbitrator *within* 3 months after completion, the claims lapse and the amount belongs to the vendor.

8 Vendor's rights and obligations

- 8.1 The vendor can *rescind* if –
- 8.1.1 the vendor is, on reasonable grounds, unable or unwilling to comply with a *requisition*;
- 8.1.2 the vendor *serves* a notice of intention to *rescind* that specifies the *requisition* and those grounds; and
- 8.1.3 the purchaser does not *serve* a notice waiving the *requisition within* 14 days after that *service*.
- 8.2 If the vendor does not comply with this contract (or a notice under or relating to it) in an essential respect, the purchaser can *terminate* by *servicing* a notice. After the *termination* –
- 8.2.1 the purchaser can recover the deposit and any other money paid by the purchaser under this contract;
- 8.2.2 the purchaser can sue the vendor to recover damages for breach of contract; and
- 8.2.3 if the purchaser has been in possession a *party* can claim for a reasonable adjustment.

9 Purchaser's default

If the purchaser does not comply with this contract (or a notice under or relating to it) in an essential respect, the vendor can *terminate* by *servicing* a notice. After the *termination* the vendor can –

- 9.1 keep or recover the deposit (to a maximum of 10% of the price);
- 9.2 hold any other money paid by the purchaser under this contract as security for anything recoverable under this clause –
- 9.2.1 for 12 months after the *termination*; or
- 9.2.2 if the vendor commences proceedings under this clause *within* 12 months, until those proceedings are concluded; and
- 9.3 sue the purchaser either –
- 9.3.1 where the vendor has resold the *property* under a contract made *within* 12 months after the *termination*, to recover –
- the deficiency on resale (with credit for any of the deposit kept or recovered and after allowance for any capital gains tax or goods and services tax payable on anything recovered under this clause); and
 - the reasonable costs and expenses arising out of the purchaser's non-compliance with this contract or the notice and of resale and any attempted resale; or
- 9.3.2 to recover damages for breach of contract.

10 Restrictions on rights of purchaser

- 10.1 The purchaser cannot make a claim or *requisition* or *rescind* or *terminate* in respect of –
- 10.1.1 the ownership or location of any fence as defined in the Dividing Fences Act 1991;
- 10.1.2 a service for the *property* being a joint service or passing through another property, or any service for another property passing through the *property* ('service' includes air, communication, drainage, electricity, garbage, gas, oil, radio, sewerage, telephone, television or water service);
- 10.1.3 a wall being or not being a party wall in any sense of that term or the *property* being affected by an easement for support or not having the benefit of an easement for support;
- 10.1.4 any change in the *property* due to fair wear and tear before completion;
- 10.1.5 a promise, representation or statement about this contract, the *property* or the title, not set out or referred to in this contract;
- 10.1.6 a condition, exception, reservation or restriction in a Crown grant;

- 10.1.7 the existence of any authority or licence to explore or prospect for gas, minerals or petroleum;
- 10.1.8 any easement or restriction on use the substance of either of which is disclosed in this contract or any non-compliance with the easement or restriction on use; or
- 10.1.9 anything the substance of which is disclosed in this contract (except a caveat, charge, mortgage, priority notice or writ).
- 10.2 The purchaser cannot *rescind* or *terminate* only because of a defect in title to or quality of the inclusions.
- 10.3 *Normally*, the purchaser cannot make a claim or *requisition* or *rescind* or *terminate* or require the vendor to change the nature of the title disclosed in this contract (for example, to remove a caution evidencing qualified title, or to lodge a plan of survey as regards limited title).
- 11 Compliance with work orders**
- 11.1 *Normally*, the vendor must by completion comply with a *work order* made on or before the contract date and if this contract is completed the purchaser must comply with any other *work order*.
- 11.2 If the purchaser complies with a *work order*, and this contract is *rescinded* or *terminated*, the vendor must pay the expense of compliance to the purchaser.
- 12 Certificates and inspections**
- The vendor must do everything reasonable to enable the purchaser, subject to the rights of any tenant –
- 12.1 to have the *property* inspected to obtain any certificate or report reasonably required;
- 12.2 to apply (if necessary in the name of the vendor) for –
- 12.2.1 any certificate that can be given in respect of the *property* under *legislation*; or
- 12.2.2 a copy of any approval, certificate, consent, direction, notice or order in respect of the *property* given under *legislation*, even if given after the contract date; and
- 12.3 to make 1 inspection of the *property* in the 3 days before a time appointed for completion.
- 13 Goods and services tax (GST)**
- 13.1 Terms used in this clause which are not defined elsewhere in this contract and have a defined meaning in the *GST Act* have the same meaning in this clause.
- 13.2 *Normally*, if a *party* must pay the price or any other amount to the other *party* under this contract, GST is not to be added to the price or amount.
- 13.3 If under this contract a *party* must make an adjustment or payment for an expense of another party or pay an expense payable by or to a third party (for example, under clauses 14 or 20.7) –
- 13.3.1 the *party* must adjust or pay on completion any GST added to or included in the expense; but
- 13.3.2 the amount of the expense must be reduced to the extent the party receiving the adjustment or payment (or the representative member of a GST group of which that party is a member) is entitled to an input tax credit for the expense; and
- 13.3.3 if the adjustment or payment under this contract is consideration for a taxable supply, an amount for GST must be added at the *GST rate*.
- 13.4 If this contract says this sale is the supply of a going concern –
- 13.4.1 the *parties* agree the supply of the *property* is a supply of a going concern;
- 13.4.2 the vendor must, between the contract date and completion, carry on the enterprise conducted on the land in a proper and business-like way;
- 13.4.3 if the purchaser is not registered by the date for completion, the *parties* must complete and the purchaser must pay on completion, in addition to the price, an amount being the price multiplied by the *GST rate* ("the retention sum"). The retention sum is to be held by the *depositholder* and dealt with as follows –
- if *within* 3 months of completion the purchaser *serves* a letter from the Australian Taxation Office stating the purchaser is registered with a date of effect of registration on or before completion, the *depositholder* is to pay the retention sum to the purchaser; but
 - if the purchaser does not *serve* that letter *within* 3 months of completion, the *depositholder* is to pay the retention sum to the vendor; and
- 13.4.4 if the vendor, despite clause 13.4.1, *serves* a letter from the Australian Taxation Office stating the vendor has to pay GST on the supply, the purchaser must pay to the vendor on demand the amount of GST assessed.
- 13.5 *Normally*, the vendor promises the margin scheme will not apply to the supply of the *property*.
- 13.6 If this contract says the margin scheme is to apply in making the taxable supply, the *parties* agree that the margin scheme is to apply to the sale of the *property*.
- 13.7 If this contract says the sale is not a taxable supply –
- 13.7.1 the purchaser promises that the *property* will not be used and represents that the purchaser does not intend the *property* (or any part of the *property*) to be used in a way that could make the sale a taxable supply to any extent; and
- 13.7.2 the purchaser must pay the vendor on completion in addition to the price an amount calculated by multiplying the price by the *GST rate* if this sale is a taxable supply to any extent because of –
- a breach of clause 13.7.1; or
 - something else known to the purchaser but not the vendor.
- 13.8 If this contract says this sale is a taxable supply in full and does not say the margin scheme applies to the *property*, the vendor must pay the purchaser on completion an amount of one-eleventh of the price if –

- 13.8.1 this sale is not a taxable supply in full; or
- 13.8.2 the margin scheme applies to the *property* (or any part of the *property*).
- 13.9 If this contract says this sale is a taxable supply to an extent –
- 13.9.1 clause 13.7.1 does not apply to any part of the *property* which is identified as being a taxable supply; and
- 13.9.2 the payments mentioned in clauses 13.7 and 13.8 are to be recalculated by multiplying the relevant payment by the proportion of the price which represents the value of that part of the *property* to which the clause applies (the proportion to be expressed as a number between 0 and 1). Any evidence of value must be obtained at the expense of the vendor.
- 13.10 *Normally*, on completion the vendor must give the recipient of the supply a tax invoice for any taxable supply by the vendor by or under this contract.
- 13.11 The vendor does not have to give the purchaser a tax invoice if the margin scheme applies to a taxable supply.
- 13.12 If the vendor is liable for GST on rents or profits due to issuing an invoice or receiving consideration before completion, any adjustment of those amounts must exclude an amount equal to the vendor's GST liability.
- 13.13 If the purchaser must make a *GSTRW payment* the purchaser must –
- 13.13.1 at least 5 days before the date for completion, *serve* evidence of submission of a *GSTRW payment* notification form to the Australian Taxation Office by the purchaser or, if a direction under clause 4.3 has been *served*, by the transferee named in the transfer *served* with that direction;
- 13.13.2 produce on completion a *settlement cheque* for the *GSTRW payment* payable to the Deputy Commissioner of Taxation;
- 13.13.3 forward the *settlement cheque* to the payee immediately after completion; and
- 13.13.4 *serve* evidence of receipt of payment of the *GSTRW payment* and a copy of the settlement date confirmation form submitted to the Australian Taxation Office.

14 Adjustments

- 14.1 *Normally*, the vendor is entitled to the rents and profits and will be liable for all rates, water, sewerage and drainage service and usage charges, land tax, levies and all other periodic outgoings up to and including the *adjustment date* after which the purchaser will be entitled and liable.
- 14.2 The *parties* must make any necessary adjustment on completion.
- 14.3 If an amount that is adjustable under this contract has been reduced under *legislation*, the *parties* must on completion adjust the reduced amount.
- 14.4 The *parties* must not adjust surcharge land tax (as defined in the Land Tax Act 1956) but must adjust any other land tax for the year current at the *adjustment date* –
- 14.4.1 only if land tax has been paid or is payable for the year (whether by the vendor or by a predecessor in title) and this contract says that land tax is adjustable;
- 14.4.2 by adjusting the amount that would have been payable if at the start of the year –
- the person who owned the land owned no other land;
 - the land was not subject to a special trust or owned by a non-concessional company; and
 - if the land (or part of it) had no separate taxable value, by calculating its separate taxable value on a proportional area basis.
- 14.5 If any other amount that is adjustable under this contract relates partly to the land and partly to other land, the *parties* must adjust it on a proportional area basis.
- 14.6 *Normally*, the vendor can direct the purchaser to produce a *settlement cheque* on completion to pay an amount adjustable under this contract and if so –
- 14.6.1 the amount is to be treated as if it were paid; and
- 14.6.2 the *cheque* must be forwarded to the payee immediately after completion (by the purchaser if the *cheque* relates only to the *property* or by the vendor in any other case).
- 14.7 If on completion the last bill for a water, sewerage or drainage usage charge is for a period ending before the *adjustment date*, the vendor is liable for an amount calculated by dividing the bill by the number of days in the period then multiplying by the number of unbilled days up to and including the *adjustment date*.
- 14.8 The vendor is liable for any amount recoverable for work started on or before the contract date on the *property* or any adjoining footpath or road.

15 Date for completion

The *parties* must complete by the date for completion and, if they do not, a *party* can *serve* a notice to complete if that *party* is otherwise entitled to do so.

16 Completion

• Vendor

- 16.1 On completion the vendor must give the purchaser any *document of title* that relates only to the *property*.
- 16.2 If on completion the vendor has possession or control of a *document of title* that relates also to other property, the vendor must produce it as and where necessary.
- 16.3 *Normally*, on completion the vendor must cause the legal title to the *property* (being an estate in fee simple) to pass to the purchaser free of any mortgage or other interest, subject to any necessary registration.
- 16.4 The legal title to the *property* does not pass before completion.

- 16.5 If the vendor gives the purchaser a document (other than the transfer) that needs to be lodged for registration, the vendor must pay the lodgment fee to the purchaser.
- 16.6 If a *party serves* a land tax certificate showing a charge on any of the land, by completion the vendor must do all things and pay all money required so that the charge is no longer effective against the land.
- **Purchaser**
- 16.7 On completion the purchaser must pay to the vendor, by cash (up to \$2,000) or *settlement cheque* –
- 16.7.1 the price less any:
- deposit paid;
 - *FRCGW remittance* payable;
 - *GSTRW payment*; and
 - amount payable by the vendor to the purchaser under this contract; and
- 16.7.2 any other amount payable by the purchaser under this contract.
- 16.8 If the vendor requires more than 5 *settlement cheques*, the vendor must pay \$10 for each extra *cheque*.
- 16.9 If any of the deposit is not covered by a bond or guarantee, on completion the purchaser must give the vendor an order signed by the purchaser authorising the *depositholder* to account to the vendor for the deposit.
- 16.10 On completion the deposit belongs to the vendor.
- **Place for completion**
- 16.11 *Normally*, the *parties* must complete at the completion address, which is –
- 16.11.1 if a special completion address is stated in this contract - that address; or
- 16.11.2 if none is stated, but a first mortgagee is disclosed in this contract and the mortgagee would usually discharge the mortgage at a particular place - that place; or
- 16.11.3 in any other case - the vendor's *solicitor's* address stated in this contract.
- 16.12 The vendor by reasonable notice can require completion at another place, if it is in NSW, but the vendor must pay the purchaser's additional expenses, including any agency or mortgagee fee.
- 16.13 If the purchaser requests completion at a place that is not the completion address, and the vendor agrees, the purchaser must pay the vendor's additional expenses, including any agency or mortgagee fee.
- 17 Possession**
- 17.1 *Normally*, the vendor must give the purchaser vacant possession of the *property* on completion.
- 17.2 The vendor does not have to give vacant possession if –
- 17.2.1 this contract says that the sale is subject to existing tenancies; and
- 17.2.2 the contract discloses the provisions of the tenancy (for example, by attaching a copy of the lease and any relevant memorandum or variation).
- 17.3 *Normally*, the purchaser can claim compensation (before or after completion) or *rescind* if any of the land is affected by a protected tenancy (a tenancy affected by Schedule 2, Part 7 of the Residential Tenancies Act 2010).
- 18 Possession before completion**
- 18.1 This clause applies only if the vendor gives the purchaser possession of the *property* before completion.
- 18.2 The purchaser must not before completion –
- 18.2.1 let or part with possession of any of the *property*;
- 18.2.2 make any change or structural alteration or addition to the *property*; or
- 18.2.3 contravene any agreement between the *parties* or any direction, document, *legislation*, notice or order affecting the *property*.
- 18.3 The purchaser must until completion –
- 18.3.1 keep the *property* in good condition and repair having regard to its condition at the giving of possession; and
- 18.3.2 allow the vendor or the vendor's authorised representative to enter and inspect it at all reasonable times.
- 18.4 The risk as to damage to the *property* passes to the purchaser immediately after the purchaser enters into possession.
- 18.5 If the purchaser does not comply with this clause, then without affecting any other right of the vendor –
- 18.5.1 the vendor can before completion, without notice, remedy the non-compliance; and
- 18.5.2 if the vendor pays the expense of doing this, the purchaser must pay it to the vendor with interest at the rate prescribed under s101 Civil Procedure Act 2005.
- 18.6 If this contract is *rescinded* or *terminated* the purchaser must immediately vacate the *property*.
- 18.7 If the *parties* or their *solicitors* on their behalf do not agree in writing to a fee or rent, none is payable.
- 19 Rescission of contract**
- 19.1 If this contract expressly gives a *party* a right to *rescind*, the *party* can exercise the right –
- 19.1.1 only by *-serving* a notice before completion; and
- 19.1.2 in spite of any making of a claim or *requisition*, any attempt to satisfy a claim or *requisition*, any arbitration, litigation, mediation or negotiation or any giving or taking of possession.
- 19.2 *Normally*, if a *party* exercises a right to *rescind* expressly given by this contract or any *legislation* –
- 19.2.1 the deposit and any other money paid by the purchaser under this contract must be refunded;
- 19.2.2 a *party* can claim for a reasonable adjustment if the purchaser has been in possession;
- 19.2.3 a *party* can claim for damages, costs or expenses arising out of a breach of this contract; and
- 19.2.4 a *party* will not otherwise be liable to pay the other *party* any damages, costs or expenses.

20 Miscellaneous

- 20.1 The *parties* acknowledge that anything stated in this contract to be attached was attached to this contract by the vendor before the purchaser signed it and is part of this contract.
- 20.2 Anything attached to this contract is part of this contract.
- 20.3 An area, bearing or dimension in this contract is only approximate.
- 20.4 If a *party* consists of 2 or more persons, this contract benefits and binds them separately and together.
- 20.5 A *party's solicitor* can receive any amount payable to the *party* under this contract or direct in writing that it is to be paid to another person.
- 20.6 A document under or relating to this contract is –
- 20.6.1 signed by a *party* if it is signed by the *party* or the *party's solicitor* (apart from a direction under clause 4.3);
- 20.6.2 *served* if it is *served* by the *party* or the *party's solicitor*;
- 20.6.3 *served* if it is *served* on the *party's solicitor*, even if the *party* has died or any of them has died;
- 20.6.4 *served* if it is *served* in any manner provided in s170 of the Conveyancing Act 1919;
- 20.6.5 *served* if it is sent by email or fax to the *party's solicitor*, unless in either case it is not received;
- 20.6.6 *served* on a person if it (or a copy of it) comes into the possession of the person; and
- 20.6.7 *served* at the earliest time it is *served*, if it is *served* more than once.
- 20.7 An obligation to pay an expense of another *party* of doing something is an obligation to pay –
- 20.7.1 if the *party* does the thing personally - the reasonable cost of getting someone else to do it; or
- 20.7.2 if the *party* pays someone else to do the thing - the amount paid, to the extent it is reasonable.
- 20.8 Rights under clauses 11, 13, 14, 17, 24, 30 and 31 continue after completion, whether or not other rights continue.
- 20.9 The vendor does not promise, represent or state that the purchaser has any cooling off rights.
- 20.10 The vendor does not promise, represent or state that any attached survey report is accurate or current.
- 20.11 A reference to any *legislation* (including any percentage or rate specified in *legislation*) is also a reference to any corresponding later *legislation*.
- 20.12 Each *party* must do whatever is necessary after completion to carry out the *party's* obligations under this contract.
- 20.13 Neither taking possession nor *servicing* a transfer of itself implies acceptance of the *property* or the title.
- 20.14 The details and information provided in this contract (for example, on pages 1 - 3) are, to the extent of each *party's* knowledge, true, and are part of this contract.
- 20.15 Where this contract provides for choices, a choice in BLOCK CAPITALS applies unless a different choice is marked.

21 Time limits in these provisions

- 21.1 If the time for something to be done or to happen is not stated in these provisions, it is a reasonable time.
- 21.2 If there are conflicting times for something to be done or to happen, the latest of those times applies.
- 21.3 The time for one thing to be done or to happen does not extend the time for another thing to be done or to happen.
- 21.4 If the time for something to be done or to happen is the 29th, 30th or 31st day of a month, and the day does not exist, the time is instead the last day of the month.
- 21.5 If the time for something to be done or to happen is a day that is not a *business day*, the time is extended to the next *business day*, except in the case of clauses 2 and 3.2.
- 21.6 *Normally*, the time by which something must be done is fixed but not essential.

22 Foreign Acquisitions and Takeovers Act 1975

- 22.1 The purchaser promises that the Commonwealth Treasurer cannot prohibit and has not prohibited the transfer under the Foreign Acquisitions and Takeovers Act 1975.
- 22.2 This promise is essential and a breach of it entitles the vendor to *terminate*.

23 Strata or community title**• Definitions and modifications**

- 23.1 This clause applies only if the land (or part of it) is a lot in a strata, neighbourhood, precinct or community scheme (or on completion is to be a lot in a scheme of that kind).
- 23.2 In this contract –
- 23.2.1 'change', in relation to a scheme, means –
- a registered or registrable change from by-laws set out in this contract;
 - a change from a development or management contract or statement set out in this contract; or
 - a change in the boundaries of common property;
- 23.2.2 'common property' includes association property for the scheme or any higher scheme;
- 23.2.3 'contribution' includes an amount payable under a by-law;
- 23.2.4 'information certificate' includes a certificate under s184 Strata Schemes Management Act 2015 and s26 Community Land Management Act 1989;
- 23.2.5 'information notice' includes a strata information notice under s22 Strata Schemes Management Act 2015 and a notice under s47 Community Land Management Act 1989;

- 23.2.6 'normal expenses', in relation to an owners corporation for a scheme, means normal operating expenses usually payable from the administrative fund of an owners corporation for a scheme of the same kind;
- 23.2.7 'owners corporation' means the owners corporation or the association for the scheme or any higher scheme;
- 23.2.8 'the *property*' includes any interest in common property for the scheme associated with the lot; and
- 23.2.9 'special expenses', in relation to an owners corporation, means its actual, contingent or expected expenses, except to the extent they are –
- normal expenses;
 - due to fair wear and tear;
 - disclosed in this contract; or
 - covered by moneys held in the capital works fund.
- 23.3 Clauses 11, 14.8 and 18.4 do not apply to an obligation of the owners corporation, or to property insurable by it.
- 23.4 Clauses 14.4.2 and 14.5 apply but on a unit entitlement basis instead of an area basis.
- **Adjustments and liability for expenses**
- 23.5 The *parties* must adjust under clause 14.1 –
- 23.5.1 a regular periodic contribution;
- 23.5.2 a contribution which is not a regular periodic contribution but is disclosed in this contract; and
- 23.5.3 on a unit entitlement basis, any amount paid by the vendor for a normal expense of the owners corporation to the extent the owners corporation has not paid the amount to the vendor.
- 23.6 If a contribution is not a regular periodic contribution and is not disclosed in this contract –
- 23.6.1 the vendor is liable for it if it was determined on or before the contract date, even if it is payable by instalments; and
- 23.6.2 the purchaser is liable for all contributions determined after the contract date.
- 23.7 The vendor must pay or allow to the purchaser on completion the amount of any unpaid contributions for which the vendor is liable under clause 23.6.1.
- 23.8 *Normally*, the purchaser cannot make a claim or *requisition* or *rescind* or *terminate* in respect of –
- 23.8.1 an existing or future actual, contingent or expected expense of the owners corporation;
- 23.8.2 a proportional unit entitlement of the lot or a relevant lot or former lot, apart from a claim under clause 6; or
- 23.8.3 a past or future change in the scheme or a higher scheme.
- 23.9 However, the purchaser can *rescind* if –
- 23.9.1 the special expenses of the owners corporation at the later of the contract date and the creation of the owners corporation when calculated on a unit entitlement basis (and, if more than one lot or a higher scheme is involved, added together), less any contribution paid by the vendor, are more than 1% of the price;
- 23.9.2 in the case of the lot or a relevant lot or former lot in a higher scheme, a proportional unit entitlement for the lot is disclosed in this contract but the lot has a different proportional unit entitlement at the contract date or at any time before completion;
- 23.9.3 a change before the contract date or before completion in the scheme or a higher scheme materially prejudices the purchaser and is not disclosed in this contract; or
- 23.9.4 a resolution is passed by the owners corporation before the contract date or before completion to give to the owners in the scheme for their consideration a strata renewal plan that has not lapsed at the contract date and there is not attached to this contract a strata renewal proposal or the strata renewal plan.
- **Notices, certificates and inspections**
- 23.10 The purchaser must give the vendor 2 copies of an information notice addressed to the owners corporation and signed by the purchaser.
- 23.11 The vendor must complete and sign 1 copy of the notice and give it to the purchaser on completion.
- 23.12 Each *party* can sign and give the notice as agent for the other.
- 23.13 The vendor must *serve* an information certificate issued after the contract date in relation to the lot, the scheme or any higher scheme at least 7 days before the date for completion.
- 23.14 The purchaser does not have to complete earlier than 7 days after *service* of the certificate and clause 21.3 does not apply to this provision. On completion the purchaser must pay the vendor the prescribed fee for the certificate.
- 23.15 The vendor authorises the purchaser to apply for the purchaser's own certificate.
- 23.16 The vendor authorises the purchaser to apply for and make an inspection of any record or other document in the custody or control of the owners corporation or relating to the scheme or any higher scheme.
- **Meetings of the owners corporation**
- 23.17 If a general meeting of the owners corporation is convened before completion –
- 23.17.1 if the vendor receives notice of it, the vendor must immediately notify the purchaser of it; and
- 23.17.2 after the expiry of any cooling off period, the purchaser can require the vendor to appoint the purchaser (or the purchaser's nominee) to exercise any voting rights of the vendor in respect of the lot at the meeting.

24 Tenancies

- 24.1 If a tenant has not made a payment for a period preceding or current at the *adjustment date* –
- 24.1.1 for the purposes of clause 14.2, the amount is to be treated as if it were paid; and
- 24.1.2 the purchaser assigns the debt to the vendor on completion and will if required give a further assignment at the vendor's expense.
- 24.2 If a tenant has paid in advance of the *adjustment date* any periodic payment in addition to rent, it must be adjusted as if it were rent for the period to which it relates.
- 24.3 If the *property* is to be subject to a tenancy on completion or is subject to a tenancy on completion –
- 24.3.1 the vendor authorises the purchaser to have any accounting records relating to the tenancy inspected and audited and to have any other document relating to the tenancy inspected;
- 24.3.2 the vendor must *serve* any information about the tenancy reasonably requested by the purchaser before or after completion; and
- 24.3.3 *normally*, the purchaser can claim compensation (before or after completion) if –
- a disclosure statement required by the Retail Leases Act 1994 was not given when required;
 - such a statement contained information that was materially false or misleading;
 - a provision of the lease is not enforceable because of a non-disclosure in such a statement; or
 - the lease was entered into in contravention of the Retail Leases Act 1994.
- 24.4 If the *property* is subject to a tenancy on completion –
- 24.4.1 the vendor must allow or transfer –
- any remaining bond money or any other security against the tenant's default (to the extent the security is transferable);
 - any money in a fund established under the lease for a purpose and compensation for any money in the fund or interest earned by the fund that has been applied for any other purpose; and
 - any money paid by the tenant for a purpose that has not been applied for that purpose and compensation for any of the money that has been applied for any other purpose;
- 24.4.2 if the security is not transferable, each *party* must do everything reasonable to cause a replacement security to issue for the benefit of the purchaser and the vendor must hold the original security on trust for the benefit of the purchaser until the replacement security issues;
- 24.4.3 the vendor must give to the purchaser –
- a proper notice of the transfer (an attornment notice) addressed to the tenant;
 - any certificate given under the Retail Leases Act 1994 in relation to the tenancy;
 - a copy of any disclosure statement given under the Retail Leases Act 1994;
 - a copy of any document served on the tenant under the lease and written details of its service, if the document concerns the rights of the landlord or the tenant after completion; and
 - any document served by the tenant under the lease and written details of its service, if the document concerns the rights of the landlord or the tenant after completion;
- 24.4.4 the vendor must comply with any obligation to the tenant under the lease, to the extent it is to be complied with by completion; and
- 24.4.5 the purchaser must comply with any obligation to the tenant under the lease, to the extent that the obligation is disclosed in this contract and is to be complied with after completion.

25 Qualified title, limited title and old system title

- 25.1 This clause applies only if the land (or part of it) –
- 25.1.1 is under qualified, limited or old system title; or
- 25.1.2 on completion is to be under one of those titles.
- 25.2 The vendor must *serve* a proper abstract of title *within 7 days* after the contract date.
- 25.3 If an abstract of title or part of an abstract of title is attached to this contract or has been lent by the vendor to the purchaser before the contract date, the abstract or part is *served* on the contract date.
- 25.4 An abstract of title can be or include a list of documents, events and facts arranged (apart from a will or codicil) in date order, if the list in respect of each document –
- 25.4.1 shows its date, general nature, names of parties and any registration number; and
- 25.4.2 has attached a legible photocopy of it or of an official or registration copy of it.
- 25.5 An abstract of title –
- 25.5.1 must start with a good root of title (if the good root of title must be at least 30 years old, this means 30 years old at the contract date);
- 25.5.2 in the case of a leasehold interest, must include an abstract of the lease and any higher lease;
- 25.5.3 *normally*, need not include a Crown grant; and
- 25.5.4 need not include anything evidenced by the Register kept under the Real Property Act 1900.
- 25.6 In the case of land under old system title –
- 25.6.1 in this contract 'transfer' means conveyance;
- 25.6.2 the purchaser does not have to *serve* the form of transfer until after the vendor has *served* a proper abstract of title; and
- 25.6.3 each vendor must give proper covenants for title as regards that vendor's interest.
- 25.7 In the case of land under limited title but not under qualified title –

- 25.7.1 *normally*, the abstract of title need not include any document which does not show the location, area or dimensions of the land (for example, by including a metes and bounds description or a plan of the land);
- 25.7.2 clause 25.7.1 does not apply to a document which is the good root of title; and
- 25.7.3 the vendor does not have to provide an abstract if this contract contains a delimitation plan (whether in registrable form or not).
- 25.8 The vendor must give a proper covenant to produce where relevant.
- 25.9 The vendor does not have to produce or covenant to produce a document that is not in the possession of the vendor or a mortgagee.
- 25.10 If the vendor is unable to produce an original document in the chain of title, the purchaser will accept a photocopy from the Registrar-General of the registration copy of that document.
- 26 Crown purchase money**
- 26.1 This clause applies only if purchase money is payable to the Crown, whether or not due for payment.
- 26.2 The vendor is liable for the money, except to the extent this contract says the purchaser is liable for it.
- 26.3 To the extent the vendor is liable for it, the vendor is liable for any interest until completion.
- 26.4 To the extent the purchaser is liable for it, the *parties* must adjust any interest under clause 14.1.
- 27 Consent to transfer**
- 27.1 This clause applies only if the land (or part of it) cannot be transferred without consent under *legislation* or a *planning agreement*.
- 27.2 The purchaser must properly complete and then *serve* the purchaser's part of an application for consent to transfer of the land (or part of it) *within 7 days* after the contract date.
- 27.3 The vendor must apply for consent *within 7 days* after *service* of the purchaser's part.
- 27.4 If consent is refused, either *party* can *rescind*.
- 27.5 If consent is given subject to one or more conditions that will substantially disadvantage a *party*, then that *party* can *rescind within 7 days* after receipt by or *service* upon the *party* of written notice of the conditions.
- 27.6 If consent is not given or refused –
- 27.6.1 *within 42 days* after the purchaser *serves* the purchaser's part of the application, the purchaser can *rescind*; or
- 27.6.2 *within 30 days* after the application is made, either *party* can *rescind*.
- 27.7 Each period in clause 27.6 becomes 90 days if the land (or part of it) is –
- 27.7.1 under a *planning agreement*, or
- 27.7.2 in the Western Division.
- 27.8 If the land (or part of it) is described as a lot in an unregistered plan, each time in clause 27.6 becomes the later of the time and 35 days after creation of a separate folio for the lot.
- 27.9 The date for completion becomes the later of the date for completion and 14 days after *service* of the notice granting consent to transfer.
- 28 Unregistered plan**
- 28.1 This clause applies only if some of the land is described as a lot in an unregistered plan.
- 28.2 The vendor must do everything reasonable to have the plan registered *within 6 months* after the contract date, with or without any minor alteration to the plan or any document to be lodged with the plan validly required or made under *legislation*.
- 28.3 If the plan is not registered *within* that time and in that manner –
- 28.3.1 the purchaser can *rescind*; and
- 28.3.2 the vendor can *rescind*, but only if the vendor has complied with clause 28.2 and with any *legislation* governing the rescission.
- 28.4 Either *party* can *serve* notice of the registration of the plan and every relevant lot and plan number.
- 28.5 The date for completion becomes the later of the date for completion and 21 days after *service* of the notice.
- 28.6 Clauses 28.2 and 28.3 apply to another plan that is to be registered before the plan is registered.
- 29 Conditional contract**
- 29.1 This clause applies only if a provision says this contract or completion is conditional on an event.
- 29.2 If the time for the event to happen is not stated, the time is 42 days after the contract date.
- 29.3 If this contract says the provision is for the benefit of a *party*, then it benefits only that *party*.
- 29.4 If anything is necessary to make the event happen, each *party* must do whatever is reasonably necessary to cause the event to happen.
- 29.5 A *party* can *rescind* under this clause only if the *party* has substantially complied with clause 29.4.
- 29.6 If the event involves an approval and the approval is given subject to a condition that will substantially disadvantage a *party* who has the benefit of the provision, the *party* can *rescind within 7 days* after either *party* *serves* notice of the condition.
- 29.7 If the *parties* can lawfully complete without the event happening –
- 29.7.1 if the event does not happen *within* the time for it to happen, a *party* who has the benefit of the provision can *rescind within 7 days* after the end of that time;
- 29.7.2 if the event involves an approval and an application for the approval is refused, a *party* who has the benefit of the provision can *rescind within 7 days* after either *party* *serves* notice of the refusal; and

- 29.7.3 the date for completion becomes the later of the date for completion and 21 days after the earliest of –
- either *party serving* notice of the event happening;
 - every *party* who has the benefit of the provision *serving* notice waiving the provision; or
 - the end of the time for the event to happen.
- 29.8 If the *parties* cannot lawfully complete without the event happening –
- 29.8.1 if the event does not happen *within* the time for it to happen, either *party* can *rescind*;
- 29.8.2 if the event involves an approval and an application for the approval is refused, either *party* can *rescind*;
- 29.8.3 the date for completion becomes the later of the date for completion and 21 days after either *party* *serves* notice of the event happening.
- 29.9 A *party* cannot *rescind* under clauses 29.7 or 29.8 after the event happens.
- 30 Electronic transaction**
- 30.1 This *Conveyancing Transaction* is to be conducted as an *electronic transaction* if –
- 30.1.1 this contract says that it is an *electronic transaction*;
- 30.1.2 the *parties* otherwise agree that it is to be conducted as an *electronic transaction*; or
- 30.1.3 the *conveyancing rules* require it to be conducted as an *electronic transaction*.
- 30.2 However, this *Conveyancing Transaction* is not to be conducted as an *electronic transaction* –
- 30.2.1 if the land is not *electronically tradeable* or the transfer is not eligible to be lodged electronically; or
- 30.2.2 if, at any time after the *effective date*, but at least 14 days before the date for completion, a *party* *serves* a notice stating a valid reason why it cannot be conducted as an *electronic transaction*.
- 30.3 If, because of clause 30.2.2, this *Conveyancing Transaction* is not to be conducted as an *electronic transaction* –
- 30.3.1 each *party* must –
- bear equally any disbursements or fees; and
 - otherwise bear that *party's* own costs;
- incurred because this *Conveyancing Transaction* was to be conducted as an *electronic transaction*; and
- 30.3.2 if a *party* has paid all of a disbursement or fee which, by reason of this clause, is to be borne equally by the *parties*, that amount must be adjusted under clause 14.2.
- 30.4 If this *Conveyancing Transaction* is to be conducted as an *electronic transaction* –
- 30.4.1 to the extent that any other provision of this contract is inconsistent with this clause, the provisions of this clause prevail;
- 30.4.2 *normally*, words and phrases used in this clause 30 (italicised and in Title Case, such as *Electronic Workspace* and *Lodgment Case*) have the same meaning which they have in the *participation rules*;
- 30.4.3 the *parties* must conduct the *electronic transaction* –
- in accordance with the *participation rules* and the *ECNL*; and
 - using the nominated *ELN*, unless the *parties* otherwise agree;
- 30.4.4 a *party* must pay the fees and charges payable by that *party* to the *ELNO* and the *Land Registry* as a result of this transaction being an *electronic transaction*;
- 30.4.5 any communication from one *party* to another *party* in the *Electronic Workspace* made –
- after the *effective date*; and
 - before the receipt of a notice given under clause 30.2.2;
- is taken to have been received by that *party* at the time determined by s13A of the *Electronic Transactions Act 2000*; and
- 30.4.6 a document which is an *electronic document* is *served* as soon as it is first *Digitally Signed* in the *Electronic Workspace* on behalf of the *party* required to *serve* it.
- 30.5 *Normally*, the vendor must *within 7 days* of the *effective date* –
- 30.5.1 create an *Electronic Workspace*;
- 30.5.2 *populate* the *Electronic Workspace* with *title data*, the date for completion and, if applicable, *mortgagee details*; and
- 30.5.3 invite the purchaser and any *discharging mortgagee* to the *Electronic Workspace*.
- 30.6 If the vendor has not created an *Electronic Workspace* in accordance with clause 30.5, the purchaser may create an *Electronic Workspace*. If the purchaser creates the *Electronic Workspace* the purchaser must –
- 30.6.1 *populate* the *Electronic Workspace* with *title data*;
- 30.6.2 create and *populate* an *electronic transfer*;
- 30.6.3 *populate* the *Electronic Workspace* with the date for completion and a nominated *completion time*; and
- 30.6.4 invite the vendor and any *incoming mortgagee* to join the *Electronic Workspace*.
- 30.7 *Normally*, *within 7 days* of receiving an invitation from the vendor to join the *Electronic Workspace*, the purchaser must –
- 30.7.1 join the *Electronic Workspace*;
- 30.7.2 create and *populate* an *electronic transfer*;
- 30.7.3 invite any *incoming mortgagee* to join the *Electronic Workspace*; and
- 30.7.4 *populate* the *Electronic Workspace* with a nominated *completion time*.

- 30.8 If the purchaser has created the *Electronic Workspace* the vendor must *within* 7 days of being invited to the *Electronic Workspace* –
- 30.8.1 join the *Electronic Workspace*;
- 30.8.2 *populate* the *Electronic Workspace* with *mortgagee details*, if applicable; and
- 30.8.3 invite any *discharging mortgagee* to join the *Electronic Workspace*.
- 30.9 To complete the financial settlement schedule in the *Electronic Workspace* –
- 30.9.1 the purchaser must provide the vendor with *adjustment figures* at least 2 *business days* before the date for completion;
- 30.9.2 the vendor must confirm the *adjustment figures* at least 1 *business day* before the date for completion; and
- 30.9.3 if the purchaser must make a *GSTRW payment* or an *FRCGW remittance*, the purchaser must *populate* the *Electronic Workspace* with the payment details for the *GSTRW payment* or *FRCGW remittance* payable to the Deputy Commissioner of Taxation at least 2 *business days* before the date for completion.
- 30.10 Before completion, the *parties* must ensure that –
- 30.10.1 all *electronic documents* which a *party* must *Digitally Sign* to complete the *electronic transaction* are *populated* and *Digitally Signed*;
- 30.10.2 all certifications required by the *ECNL* are properly given; and
- 30.10.3 they do everything else in the *Electronic Workspace* which that *party* must do to enable the *electronic transaction* to proceed to completion.
- 30.11 If completion takes place in the *Electronic Workspace* –
- 30.11.1 payment electronically on completion of the price in accordance with clause 16.7 is taken to be payment by a single *settlement cheque*;
- 30.11.2 the completion address in clause 16.11 is the *Electronic Workspace*; and
- 30.11.3 clauses 13.13.2 to 13.13.4, 16.8, 16.12, 16.13 and 31.2.2 to 31.2.4 do not apply.
- 30.12 If the computer systems of any of the *Land Registry*, the *ELNO* or the Reserve Bank of Australia are inoperative for any reason at the *completion time* agreed by the *parties*, a failure to complete this contract for that reason is not a default under this contract on the part of either *party*.
- 30.13 If the computer systems of the *Land Registry* are inoperative for any reason at the *completion time* agreed by the *parties*, and the *parties* choose that financial settlement is to occur despite this, then on financial settlement occurring –
- 30.13.1 all *electronic documents Digitally Signed* by the vendor, the *certificate of title* and any discharge of mortgage, withdrawal of caveat or other *electronic document* forming part of the *Lodgment Case* for the *electronic transaction* shall be taken to have been unconditionally and irrevocably delivered to the purchaser or the purchaser's mortgagee at the time of financial settlement together with the right to deal with the land comprised in the *certificate of title*; and
- 30.13.2 the vendor shall be taken to have no legal or equitable interest in the *property*.
- 30.14 A *party* who holds a *certificate of title* must act in accordance with any *Prescribed Requirement* in relation to the *certificate of title* but if there is no *Prescribed Requirement*, the vendor must *serve* the *certificate of title* after completion.
- 30.15 If the *parties* do not agree about the delivery before completion of one or more documents or things that cannot be delivered through the *Electronic Workspace*, the *party* required to deliver the documents or things –
- 30.15.1 holds them on completion in escrow for the benefit of; and
- 30.15.2 must immediately after completion deliver the documents or things to, or as directed by; the *party* entitled to them.
- 30.16 In this clause 30, these terms (in any form) mean –
- | | |
|------------------------------|---|
| <i>adjustment figures</i> | details of the adjustments to be made to the price under clause 14; |
| <i>certificate of title</i> | the paper duplicate of the folio of the register for the land which exists immediately prior to completion and, if more than one, refers to each such paper duplicate; |
| <i>completion time</i> | the time of day on the date for completion when the <i>electronic transaction</i> is to be settled; |
| <i>conveyancing rules</i> | the rules made under s12E of the Real Property Act 1900; |
| <i>discharging mortgagee</i> | any discharging mortgagee, chargee, covenant chargee or caveator whose provision of a <i>Digitally Signed</i> discharge of mortgage, discharge of charge or withdrawal of caveat is required in order for unencumbered title to the <i>property</i> to be transferred to the purchaser; |
| <i>ECNL</i> | the Electronic Conveyancing National Law (NSW); |
| <i>effective date</i> | the date on which the <i>Conveyancing Transaction</i> is agreed to be an <i>electronic transaction</i> under clause 30.1.2 or, if clauses 30.1.1 or 30.1.3 apply, the contract date; |
| <i>electronic document</i> | a dealing as defined in the Real Property Act 1900 which may be created and <i>Digitally Signed</i> in an <i>Electronic Workspace</i> ; |
| <i>electronic transfer</i> | a transfer of land under the Real Property Act 1900 for the <i>property</i> to be prepared and <i>Digitally Signed</i> in the <i>Electronic Workspace</i> established for the purposes of the <i>parties' Conveyancing Transaction</i> ; |

<i>electronic transaction</i>	a <i>Conveyancing Transaction</i> to be conducted for the <i>parties</i> by their legal representatives as <i>Subscribers</i> using an <i>ELN</i> and in accordance with the <i>ECNL</i> and the <i>participation rules</i> ;
<i>electronically tradeable</i>	a land title that is Electronically Tradeable as that term is defined in the <i>conveyancing rules</i> ;
<i>incoming mortgagee</i>	any mortgagee who is to provide finance to the purchaser on the security of the <i>property</i> and to enable the purchaser to pay the whole or part of the price;
<i>mortgagee details</i>	the details which a <i>party</i> to the <i>electronic transaction</i> must provide about any <i>discharging mortgagee</i> of the <i>property</i> as at completion;
<i>participation rules</i>	the participation rules as determined by the <i>ECNL</i> ;
<i>populate</i>	to complete data fields in the <i>Electronic Workspace</i> ; and
<i>title data</i>	the details of the title to the <i>property</i> made available to the <i>Electronic Workspace</i> by the <i>Land Registry</i> .

31 Foreign Resident Capital Gains Withholding

- 31.1 This clause applies only if –
- 31.1.1 the sale is not an excluded transaction within the meaning of s14-215 of Schedule 1 to the *TA Act*, and
- 31.1.2 a *clearance certificate* in respect of every vendor is not attached to this contract.
- 31.2 The purchaser must –
- 31.2.1 at least 5 days before the date for completion, serve evidence of submission of a purchaser payment notification to the Australian Taxation Office by the purchaser or, if a direction under clause 4.3 has been served, by the transferee named in the transfer served with that direction;
- 31.2.2 produce on completion a *settlement cheque* for the *FRCGW remittance* payable to the Deputy Commissioner of Taxation;
- 31.2.3 forward the *settlement cheque* to the payee immediately after completion; and
- 31.2.4 serve evidence of receipt of payment of the *FRCGW remittance*.
- 31.3 The vendor cannot refuse to complete if the purchaser complies with clauses 31.2.1 and 31.2.2.
- 31.4 If the vendor serves any *clearance certificate* or *variation*, the purchaser does not have to complete earlier than 7 days after that service and clause 21.3 does not apply to this provision.
- 31.5 If the vendor serves in respect of every vendor either a *clearance certificate* or a *variation* to 0.00 percent, clauses 31.2 and 31.3 do not apply.

32 Residential off the plan contract

- 32.1 This clause applies if this contract is an off the plan contract within the meaning of Division 10 of Part 4 of the Conveyancing Act 1919 (the Division).
- 32.2 No provision of this contract has the effect of excluding, modifying or restricting the operation of the Division.
- 32.3 If the purchaser makes a claim for compensation under the terms prescribed by clause 6A of the Conveyancing (Sale of Land) Regulation 2017 –
- 32.3.1 the purchaser cannot make a claim under this contract about the same subject matter, including a claim under clauses 6 or 7; and
- 32.3.2 the claim for compensation is not a claim under this contract.
- 32.4 This clause does not apply to a contract made before the commencement of the amendments to the Division under the Conveyancing Legislation Amendment Act 2018.

SECTION 66W CERTIFICATE

I,
of , , certify as follows:

1. I am a _____ currently admitted to practise in New South Wales;
2. I am giving this certificate in accordance with section 66W of the Conveyancing Act 1919 with reference to a contract for the sale of property at 17/11-13 HOLBORN AVE DEE WHY NSW 2099 from MITSUYOSHI HABADERA to in order that there is no cooling off period in relation to that contract;
3. I do not act for MITSUYOSHI HABADERA and am not employed in the legal practice of a solicitor acting for MITSUYOSHI HABADERA nor am I a member or employee of a firm of which a solicitor acting for MITSUYOSHI HABADERA is a member or employee; and
4. I have explained to :
 - (a) The effect of the contract for the purchase of that property;
 - (b) The nature of this certificate; and
 - (c) The effect of giving this certificate to the vendor, i.e. that there is no cooling off period in relation to the contract.

Date:

SPECIAL CONDITIONS

30 Purchaser's acknowledgments

- 30.1 The purchaser agrees and acknowledges that no reliance has been made upon any warranty or representation made by the vendor or any person on behalf of the vendor except as expressly provided in this contract. This contract constitutes the whole agreement between the parties and the purchaser has relied entirely upon the purchaser's own enquiries relating to, and in the inspection of, the property, all improvements and any items of inclusion referred to on the front page of this contract and in relation to the use to which the property may be put.
- 30.2 The purchaser acknowledges that the purchaser is purchasing the property in its present state of repair and condition and will make no objection, requisition or claim for compensation concerning the state of repair or condition of the property or any latent or patent defect in quality in the property.
- 30.3 The purchaser must satisfy him/herself on all matters (including availability of service) relating to the use of the property and acknowledges that the vendor gives no warranty as to the use to which the property may be put.

The purchaser will be deemed to have entered into this Contract with full knowledge of and subject to any prohibition or restriction upon the use of the property, whether under any Act, Ordinance, Regulation, By-law, Town Planning Scheme, Interim Development Order, Order of Court, or otherwise.

If the use to which the vendor has put the property is permissible only with the consent of any authority under any Act, Ordinance, Regulation, By-law, Town Planning Scheme, Interim Development Order, Order of Court, or otherwise, the purchaser must obtain consent at the purchaser's own expense.

Completion of this Contract will not be conditional or dependent upon any matter referred to in this clause.

- 30.4 The Vendor discloses to the purchaser that State Environmental Planning Policy 28 has been repealed and that some of the provisions of State Environmental Planning Policy 25 and Sydney Regional Environmental Plan 12 that allowed subdivision of dual occupancies have been repealed and that the attached certificate under S149 of the Environmental Planning and Assessment Act 1979 may be inaccurate in respect of those matters. The Purchaser shall not raise any requisition or objection nor make any claim for compensation in respect of any such inaccuracy.
- 30.5 For avoidance of doubt, if there is a swimming pool or spa on the Property, the Vendor does not warrant that the swimming pool on the Property complies with the requirements imposed by the Swimming Pools Act 1992 (NSW) or any current Act in relation to swimming pools. The Purchaser agrees that after Completion, it will comply with any statutory requirement relating to access to the swimming pool and the erection of a warning notice. The Purchaser must accept the swimming pool (including its fences, gates and various paraphernalia as they exist at the date of the

Contract) in its present conditions despite any notice issued by a competent authority before Completion relating to the swimming pool.

31 Interest & Charges

- 31.1 the Purchaser pay to the vendor on completion, unless the delay is solely caused by the Vendor, in addition to the other moneys payable under this contract, the amount obtained by applying a simple interest formula of 10% per annum to the balance of the price and calculated on a daily basis from but not including the completion date stipulated on this contract to and including the date upon which this contract is completed.
- 31.2 If the Purchaser requests the Vendor to complete the Contract at a location other than the location nominated by the Vendor and the Vendor in its absolute discretion agrees to do so, then the Purchaser must allow an additional completion fee of \$110 (GST inclusive) to the Vendor and must reimburse the Vendor any such costs incurred by the Vendor as a result of accommodating the Purchaser's request.
- 31.3 If the Purchaser fails to attend or effect settlement (through no fault of the Vendor) after settlement arrangement has been arranged, the Purchaser must allow on Completion to the Vendor an amount of \$110 (GST inclusive) for each time a failure occurs. This amount represents the additional legal costs incurred by the Vendor for each additional settlement Vendor's Solicitors are required to attend for the Vendor.
- 31.4 This clause 31 is an essential term of the Contract.

32 Agent

- 32.1 The purchaser warrants to the vendor that the purchaser has not been introduced to the property by any real estate agent except the vendor's agent named in this contract and the purchaser indemnifies the vendor against any claim for commission which might be made by an agent resulting from an introduction forming a breach of such warranty and against all costs and expenses incidental to defending such a claim.

33 Foreign persons

- 33.1 The purchaser warrants that the provisions of the Foreign Acquisitions and Takeovers Act, 1975 requiring the obtaining of consent to this transaction do not apply to the purchaser and this purchase.
- 33.2 In the event of there being a breach of this warranty, whether deliberately or unintentionally, the purchaser agrees to indemnify and compensate the vendor in respect of any loss, damage, penalty, fine or legal costs, which may be incurred by the vendor as a consequence thereof.

34 Notice to complete

- 34.1 It is hereby agreed that the notice to complete provision referred to in Clause 15 hereof shall be a fourteen (14) day notice to complete making time of the essence of this contract and such time shall be deemed sufficient and reasonable by both parties, at law and equity.
- 34.2 If completion of this contract takes places after the completion date and a Notice to Complete is issued by the vendor, it is an essential condition of this contract that the

vendor shall be entitled to recover from the purchasers as liquidated damages payable on completion the sum of three hundred and thirty dollars (\$330.00) inclusive of GST to cover legal additional costs and other expenses incurred by the Vendor as a consequence of issuing a Notice to Complete against the Purchaser. The amount is to be allowed by the purchaser as an additional adjustment on completion.

35 Amendments to printed Forms

- 35.1 For all purposes of the this contract, the terms of the printed contract to which these clauses are annexed are amended as follows:
- 35.2 Clauses 2.2 and 4.1 to be amended by deleting the word "Normally".
- 35.3 Clause 7.1.1 be deleted entirely;
- 35.4 Clause 8 be amended by deleting the words "on reasonable grounds" in the first line of clause 8.1 and deleting the words "and those grounds" in the first line of clause 8.2;
- 35.5 Clause 12.1 and 12.2 be deleted entirely;
- 35.6 Clause 14.1 to be amended by adding "This clause shall not merge on completion."
- 35.7 Clause 14.4.2 be amended by replacing the first bullet point with "if the vendor owns other properties, the amount payable by the purchaser shall be determined in accordance with the following formulas:

T = A x B/C where

T= land tax amount payable by the purchaser on Completion
A= total land tax payable by the vendor in the relevant land tax year.
B= the land tax value of the Property hereby sold
C= the total land tax value of all properties owned by the vendor
(excluding any properties that are exempted from land tax assessment)."

- 35.8 Clause 16.5 be amended by deleting the words "plus another 20% of that fee";
- 35.9 Clause 16.6 be amended by adding "at least 7 days before completion" after "land";
- 35.10 Clause 16.8 be deleted entirely;
- 35.11 Clause 18.7 be amended by substituting "the rent or fee payable is 0.002% of the purchase price per week" for the words "none is payable";
- 35.12 Clause 23.13 & 23.14 be deleted entirely.

36 Regulations

- 36.1 The purchaser(s) warrant that all pages of all documents required to be included in this Contract by the *Conveyancing (Sale of Land) Regulation 2005* have been included.

37 Deposit

37.1 The Parties agree that the deposit payable pursuant to this Contract is ten per cent (10%) of the Price. If the Vendor agrees, the Purchaser may pay the 10% deposit by instalments in the following manner:

- Five percent (5%) on exchange; and
- The balance five percent (5%) shall be payable on the earlier of the date of Completion, or the date when the Vendor demands payment following the default by the Purchaser in the observance or performance of any of its obligation under this contract.

If the purchaser has paid a deposit less than ten (10%) of the purchase price and in the event the vendor becomes entitled to terminate this agreement then the vendor shall be entitled, in addition to any rights and remedies available at law or equity, to sue the purchaser for the difference between ten 10% of the purchase price and the amount of deposit actually paid.

37.2 The purchaser hereby agrees to release to the vendor the deposit moneys paid herein for the purpose of deposit or stamp duty payable on the purchase of another property by the vendor, if required, provided that such amount shall only be paid into the account of Office of State Revenue or the trust account of a solicitor or real estate agent. The purchaser agrees that this clause is sufficient authority for the vendor's agent to release the deposit and that no further authority from the purchaser is required.

38 Requisitions

38.1 For the purpose of clause 5.1 the requisitions or general questions about the property or the title must be in the form of the attached requisitions.

39 Guarantee & Indemnity

39.1 If the purchaser is a company, then the provisions of this clause 39 apply and the directors of the purchaser company (both jointly and severally) shall be known as "the Guarantor"

39.2 The Guarantor acknowledges incurring obligations and giving rights under this guarantee and indemnity for valuable consideration received from the vendor including, without Limitation, the agreement of the vendor to enter into this contract.

39.3 The Guarantor unconditionally and irrevocably guarantees payment to the vendor of the Guaranteed Money and unconditionally and irrevocably guarantees the due and punctual performance of the purchaser's obligations under this contract.

39.4 If the purchaser does not pay the Guaranteed Money on time and in accordance with the terms of this contract, then the Guarantor agrees to pay the Guaranteed Money to the vendor on demand from the vendor (whether or not demand has been made on the purchaser). A demand may be made at any time and from time to time.

39.5 If the purchaser does not duly and punctually perform its obligations in accordance with the terms of the document under which they are to be performed then the guarantor agrees to perform those obligations on demand from the vendor (whether or not demand has been made on the purchaser). A demand may be made at any time and from time to time.

- 39.6 As a separate undertaking, the guarantor indemnifies the vendor against:
- (a) all liability or loss arising from, and any costs, charges or expenses incurred in connection with, the Guaranteed Money not being recoverable from the Guarantor under clauses 39.4 and 39.5 or from the purchaser because of any circumstance whatsoever; and
 - (b) all liability or loss arising from, and any costs, charges or expenses incurred in connection with the Guarantor's and / or the purchaser's obligations not being duly and punctually performed because of any circumstance whatsoever.
 - (c) This guarantee and indemnity is a continuing security and extends to all of the Guaranteed Money and other money payable under this guarantee and indemnity and to all of the Guarantor's obligations. The guarantor waives any right it has of first requiring the vendor to proceed against or enforce any other right, power, remedy or security or claim payment from the purchaser or any other person before claiming from the guarantor under this guarantee and indemnity.
- 39.7 The liabilities under this guarantee and indemnity of the Guarantor as a guarantor, principal debtor, principal obligor or indemnifier and the rights of the vendor under this guarantee and indemnity are not affected by anything which might otherwise affect them at law or equity including, without limitation, one or more of the following:
- (a) the vendor or another person granting time or other indulgence to, compounding or compromising with or releasing the purchaser;
 - (b) acquiescence, delay, acts, omissions or mistakes on the part of the vendor; or
 - (c) any variation or novation of a right of the vendor, or alteration of this contract or a document, in respect of the purchaser.
- 39.8 as long as the Guaranteed Money or other money payable under this guarantee and indemnity remains unpaid or the obligations of the purchaser or any of them remain unperformed, the guarantor may not, without the consent of the vendor:
- (a) make a claim or enforce a right (including, without limitation, a mortgage, charge or other encumbrance) against the purchaser or its property; or
 - (b) prove in competition with the vendor if a liquidator, provisional liquidator, official manager or trustee in bankruptcy is appointed in respect of the purchaser or the purchaser is otherwise unable to pay its debts when they fall due.
- 39.9 The Guarantor represents and warrants that its obligations under this guarantee and indemnity are valid and binding and that it does not enter into this guarantee and indemnity in the capacity of a trustee of any trust or settlement.
- 39.10 This clause 39 is an essential term of this contract.

40 Finance

- 40.1 The Purchaser expressly warrants to the Vendor that they either hold a current loan approval in an amount and upon terms which they consider to be reasonable and fully satisfactory and sufficient to enable completion of this contract within the time

stipulated and upon the terms and conditions set out herein or do not require finance to complete this Contract.

40.2 The Purchaser acknowledges that the Vendor relies upon this warranty in entering into this Contract and that the Vendor may enter into further contractual obligations on or after the date of this contract in reliance upon this warranty.

40.3 The Purchaser further acknowledges that it shall remain liable to the Vendor for all damages arising from breach of this warranty notwithstanding any right which the Purchaser may have pursuant to the Uniform Credit Code.

41 GST

41.1 In this clause:

“GST” refers to the Goods and Services Tax under a *New Tax System (Goods and Services Tax) Act 1999* (“GST Act”) and the terms used hereunder have the meanings as defined in the GST Act.

41.2 The vendor is and has been occupying the property as a residence and it is residential premises under the GST Act.

41.3 The purchaser agrees, on and after completion of this sale, to use the property predominantly for residential accommodation.

41.4 In the event of the vendor being liable for GST, because of the purchaser’s failure to comply with clause 41.3:

(a) The purchaser agrees to pay to the vendor within 14 days after the vendor’s liability for GST on this sale is confirmed by correspondence or assessment from the Commissioner, the amount of the GST, including any additional penalty and interest.

(b) The vendor shall deliver to the purchaser, as a precondition to such payment, a tax invoice in a form, which complies with the GST Act and regulations.

42 Caveat

42.1 The Purchaser must not register any caveat against any of the Certificate of Title relating to the Land or Property notifying its interest under the Contract. This is an essential term of the Contract.

43 Special Levy

43.1 Where a special levy is payable from the date of this Contract, the Purchaser shall be responsible for such special levy. This clause shall not merge on completion.

44 Merger

44.1 The rights and obligations of the parties will not merge on completion of this Contract. All clauses of this Contract will have application after completion for as long as necessary to give effect to the operation of those provisions.

45 Inconsistency

45.1 If there is any inconsistency between these Special Conditions and the standard conditions and terms of the printed Contract for the Sale of Land which these special Conditions form a part, then these Special Conditions shall prevail.

46 Purchaser to obtain s184 Strata Schemes Management Act 2015 / s26 Community Land Management Act 1989

46.1 The Purchaser is under obligation to obtain a s184 Information Certificate, the Vendor discloses to the Purchaser that the Vendor will not obtain the said certificate. The Vendor authorises the Purchaser to contact the Strata Manager and body corporation in order to obtain the Information Certificate for adjustment purposes.

Execution by the Guarantors

_____ and _____ acknowledge that by signing this document they provide a guarantee. They further acknowledge that by signing this document, they have sought and received independent legal advice on their obligations as guarantors.

Signed by _____)
Guarantor in the presence _____)
of _____)

.....

.....

Witness

.....

Full Name of Witness

.....

Address of Witness

STRATA TITLE (RESIDENTIAL) PROPERTY REQUISITIONS ON TITLE

Vendor:

Purchaser:

Property:

Dated:

Possession and tenancies

1. Vacant possession of the property must be given on completion unless the Contract provides otherwise.
2. Is anyone in adverse possession of the property or any part of it?
3.
 - (a) What are the nature and provisions of any tenancy or occupancy?
 - (b) If they are in writing, all relevant documentation should be produced, found in order and handed over on completion with notices of attornment.
 - (c) Please specify any existing breaches.
 - (d) All rent should be paid up to or beyond the date of completion.
 - (e) Please provide details of any bond together with the Rental Bond Board's reference number.
 - (f) If any bond money is held by the Rental Bond Board, the appropriate transfer documentation duly signed should be handed over on completion.
4. Is the property affected by a protected tenancy? (A tenancy affected by Parts 2, 3, 4 or 5 of the *Landlord and Tenant (Amendment) Act 1948*.)
5. If the tenancy is subject to the *Residential Tenancies Act 1987*:
 - (a) has either the vendor or any predecessor or the tenant applied to the Residential Tenancies Tribunal for an order?
 - (b) have any orders been made by the Residential Tenancies Tribunal? If so, please provide details.

Title

6. Subject to the Contract, on completion the vendor should be registered as proprietor in fee simple of the property and recorded as the owner of the property on the strata roll, free of all other interests.
7. On or before completion, any mortgage or caveat or writ must be discharged, withdrawn or cancelled (as the case may be) or, in the case of a mortgage or caveat, an executed discharge or withdrawal handed over on completion together with a notice under Section 118 of the *Strata Schemes Management Act 1996 (the Act)*.
8. Are there any proceedings pending or concluded that could result in the recording of any writ on the title to the property or in the General Register of Deeds? If so, full details should be provided at least 14 days prior to completion.
9. When and where may the title documents be inspected?
10. Are the inclusions or fixtures subject to any charge or hiring agreement? If so, details must be given and any indebtedness discharged prior to completion or title transferred unencumbered to the vendor prior to completion.

Adjustments

11. All outgoings referred to in clause 14.1 of the Contract must be paid up to and including the date of completion.
12. Is the vendor liable to pay land tax or is the property otherwise charged or liable to be charged with land tax? If so:
 - (a) to what year has a return been made?
 - (b) what is the taxable value of the property for land tax purposes for the current year?

Survey and building

13. Subject to the Contract, survey should be satisfactory and show that the whole of the property and the common property is available, that there are no encroachments by or upon the property or the common property and that all improvements comply with local government/planning legislation.
14. Is the vendor in possession of a survey report? If so, please produce a copy for inspection prior to completion. The original should be handed over on completion.
15. In respect of the property and the common property:
 - (a) Have the provisions of the *Local Government Act*, the *Environmental Planning and Assessment Act 1979* and their regulations been complied with?
 - (b) Is there any matter that could justify the making of an upgrading or demolition order in respect of any building or structure?
 - (c) Has the vendor a Building Certificate which relates to all current buildings or structures? If so, it should be handed over on completion. Please provide a copy in advance.
 - (d) Has the vendor a Final Occupation Certificate issued under the *Environmental Planning and Assessment Act 1979* for all current buildings or structures? If so, it should be handed over on completion. Please provide a copy in advance.
 - (e) In respect of any residential building work carried out in the last 7 years:
 - (i) please identify the building work carried out;
 - (ii) when was the building work completed?
 - (iii) please state the builder's name and licence number;

- (iv) please provide details of insurance under the *Home Building Act 1989*.
16. Has the vendor (or any predecessor) or the Owners Corporation entered into any agreement with or granted any indemnity to the Council or any other authority concerning any development on the property or the common property?
17. If a swimming pool is on the common property:
- (a) when did construction of the swimming pool commence?
 - (b) is the swimming pool surrounded by a barrier which complies with the requirements of the *Swimming Pools Act 1992*?
 - (c) if the swimming pool has been approved under the *Local Government Act 1993*, please provide details.
 - (d) are there any outstanding notices or orders?
18. (a) If there are any party walls, please specify what rights exist in relation to each party wall and produce any agreement. The benefit of any such agreement should be assigned to the purchaser on completion.
- (b) Is the vendor aware of any dispute regarding boundary or dividing fences or party walls?
 - (c) Has the vendor received any notice, claim or proceedings under the *Dividing Fences Act 1991* or the *Encroachment of Buildings Act 1922*?

Affectations, notices and claims

19. In respect of the property and the common property:
- (a) Is the vendor aware of any rights, licences, easements, covenants or restrictions as to use of them other than those disclosed in the Contract?
 - (b) Has any claim been made by any person to close, obstruct or limit access to or from them or to prevent the enjoyment of any easement appurtenant to them?
 - (c) Is the vendor aware of:
 - (i) any road, drain, sewer or storm water channel which intersects or runs through them?
 - (ii) any dedication to or use by the public of any right of way or other easement over any part of them?
 - (iii) any latent defects in them?
 - (d) Has the vendor any notice or knowledge of them being affected by the following:
 - (i) any resumption or acquisition or proposed resumption or acquisition?
 - (ii) any notice requiring work to be done or money to be spent on them or any footpath or road adjoining? If so, such notice must be complied with prior to completion.
 - (iii) any work done or intended to be done on them or the adjacent street which may create a charge on them or the cost of which might be or become recoverable from the purchaser?
 - (iv) any sum due to any local or public authority recoverable from the purchaser? If so, it must be paid prior to completion.
 - (v) any realignment or proposed realignment of any road adjoining them?
 - (vi) any contamination of them?

Owners corporation management

20. Has the initial period expired?
21. If the property includes a utility lot, please specify the restrictions.
22. If there are any applications or orders under Chapter 5 of the Act, please provide details.
23. Do any special expenses (as defined in clause 23.2 of the Contract) exceed 1% of the price?

Capacity

24. If the Contract discloses that the vendor is a trustee, evidence should be produced to establish the trustee's power of sale.

Requisitions and transfer

25. If the transfer or any other document to be handed over on completion is executed pursuant to a power of attorney, then at least 7 days prior to completion a copy of the registered power of attorney should be produced and found in order.
26. If the vendor has or is entitled to have possession of the title deeds the Certificate Authentication Code must be provided 7 days prior to settlement.
27. Searches, surveys, enquiries and inspection of title deeds must prove satisfactory.
28. The purchaser reserves the right to make further requisitions prior to completion.
29. Unless we are advised by you to the contrary prior to completion, it will be assumed that your replies to these requisitions remain unchanged as at completion date.



FOLIO: 17/SP80483

SEARCH DATE	TIME	EDITION NO	DATE
1/6/2020	9:59 AM	5	15/9/2018

NO CERTIFICATE OF TITLE HAS ISSUED FOR THE CURRENT EDITION OF THIS FOLIO.
CONTROL OF THE RIGHT TO DEAL IS HELD BY CITIGROUP PTY LIMITED.

LAND

LOT 17 IN STRATA PLAN 80483
AT DEE WHY
LOCAL GOVERNMENT AREA NORTHERN BEACHES

FIRST SCHEDULE

MITSUYOSHI HABADERA (T AG675685)

SECOND SCHEDULE (2 NOTIFICATIONS)

- 1 INTERESTS RECORDED ON REGISTER FOLIO CP/SP80483
- 2 AI276473 MORTGAGE TO CITIGROUP PTY LIMITED

NOTATIONS

UNREGISTERED DEALINGS: NIL

*** END OF SEARCH ***



FOLIO: 17/SP80483

SEARCH DATE	TIME	EDITION NO	DATE
-----	----	-----	----
1/6/2020	9:59 AM	5	15/9/2018

NO CERTIFICATE OF TITLE HAS ISSUED FOR THE CURRENT EDITION OF THIS FOLIO.
CONTROL OF THE RIGHT TO DEAL IS HELD BY CITIGROUP PTY LIMITED.

LAND

LOT 17 IN STRATA PLAN 80483
AT DEE WHY
LOCAL GOVERNMENT AREA NORTHERN BEACHES

FIRST SCHEDULE

MITSUYOSHI HABADERA (T AG675685)

SECOND SCHEDULE (2 NOTIFICATIONS)

- 1 INTERESTS RECORDED ON REGISTER FOLIO CP/SP80483
- 2 AI276473 MORTGAGE TO CITIGROUP PTY LIMITED

NOTATIONS

UNREGISTERED DEALINGS: NIL

*** END OF SEARCH ***

STRATA PLAN FORM 2 (A3)

WARNING: CREASING OR FOLDING WILL LEAD TO REJECTION

Sheet 1 of 5 sheets

LOCATION PLAN

S.P. 7055

M.G.A.

HOLBORN AVENUE

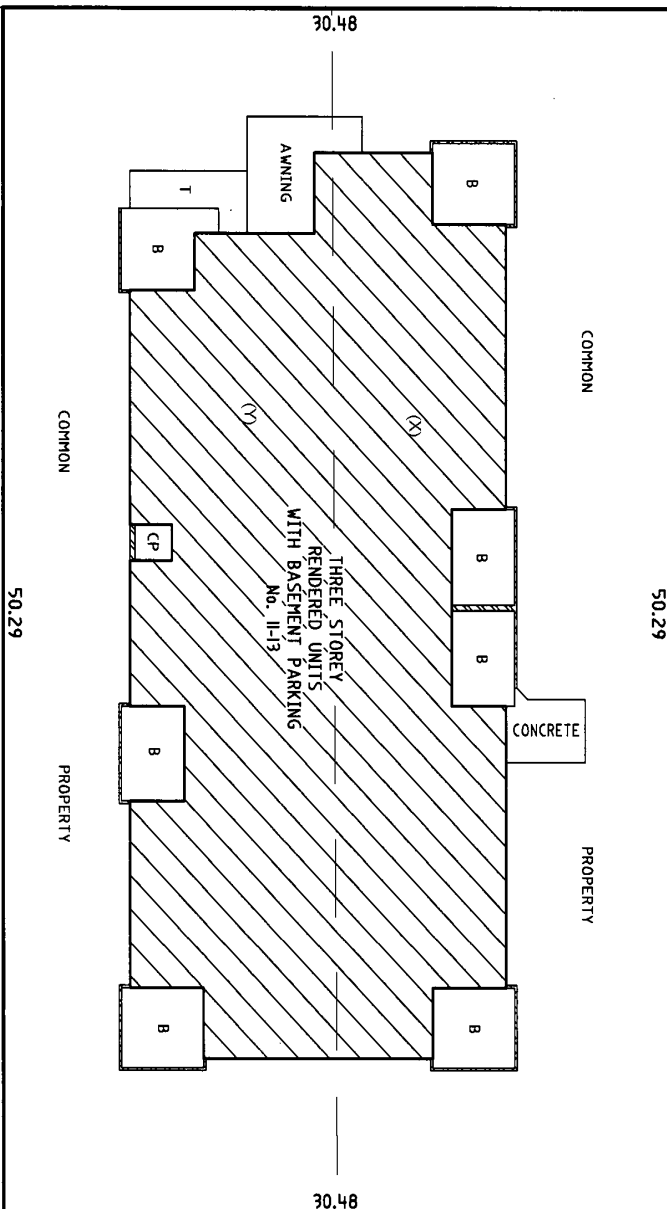

S.P. 22576

S.P. 5069

S.P. 5378

- B - DENOTES BALCONY
- P - DENOTES PLANTER
- T - DENOTES TERRACE
- CP - DENOTES COMMON PROPERTY

- (X) - COVENANT A899571
- (Y) - COVENANT A937482

10 20 30 40 50 60 70 80 90 100 110 120 130 140 Table of mm

Surveyor: Warren L. Bee
 Surveyor's Ref: 16041SP
 Subdivision No: 50167
 Lengths are in metres Reduction Ratio 1: 200

Registered
 10.4.2008

SP80483 P

STRATA PLAN FORM 2 (A3)

WARNING: CREASING OR FOLDING WILL LEAD TO REJECTION

BASEMENT LEVEL

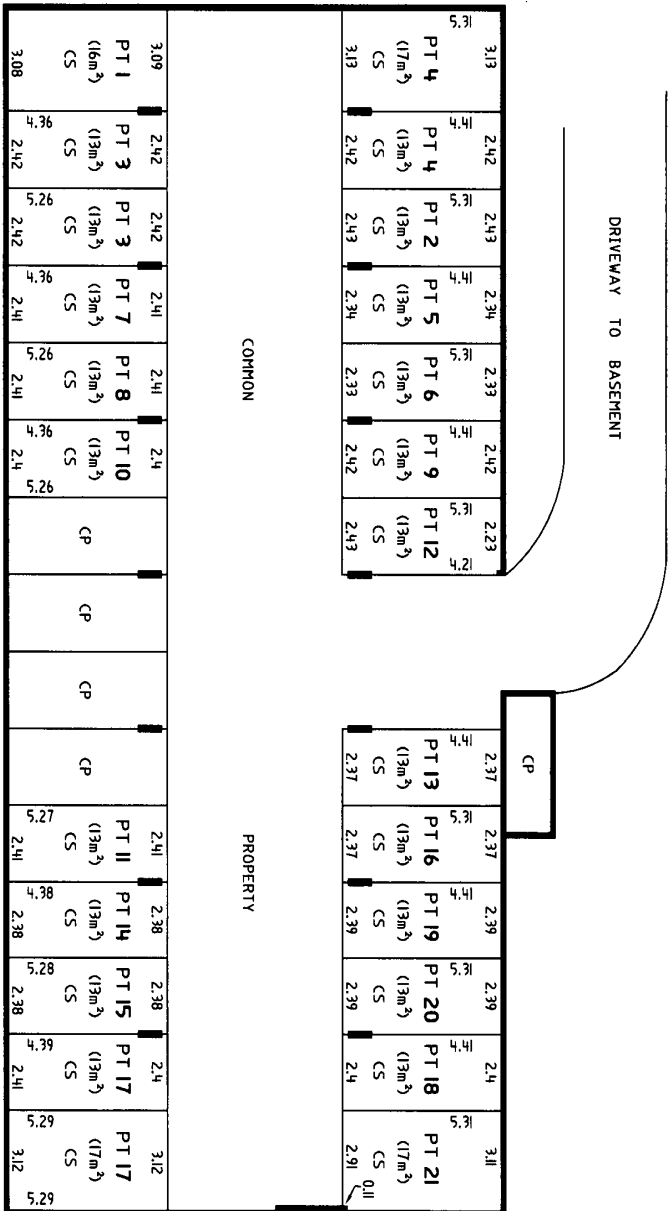

CS - DENOTES CARSPACE
 CP - DENOTES COMMON PROPERTY



DENOTES PROLONGATION OF
 CENTRE LINE OF COLUMN

**CAUTION: THE AREAS SHOWN ARE FOR THE PURPOSE OF
 THE STRATA TITLES ACT ONLY AND ARE APPROXIMATE**

10	20	30	40	50	Table of mm	90	100	110	120	130	140
----	----	----	----	----	-------------	----	-----	-----	-----	-----	-----

Surveyor: Warren L. Bee
 Surveyor's Ref: 16041SP
 Subdivision No: 5C/167
 Lengths are in metres Reduction Ratio 1:150

Registered
 10.4.2008

SP80483

GROUND FLOOR

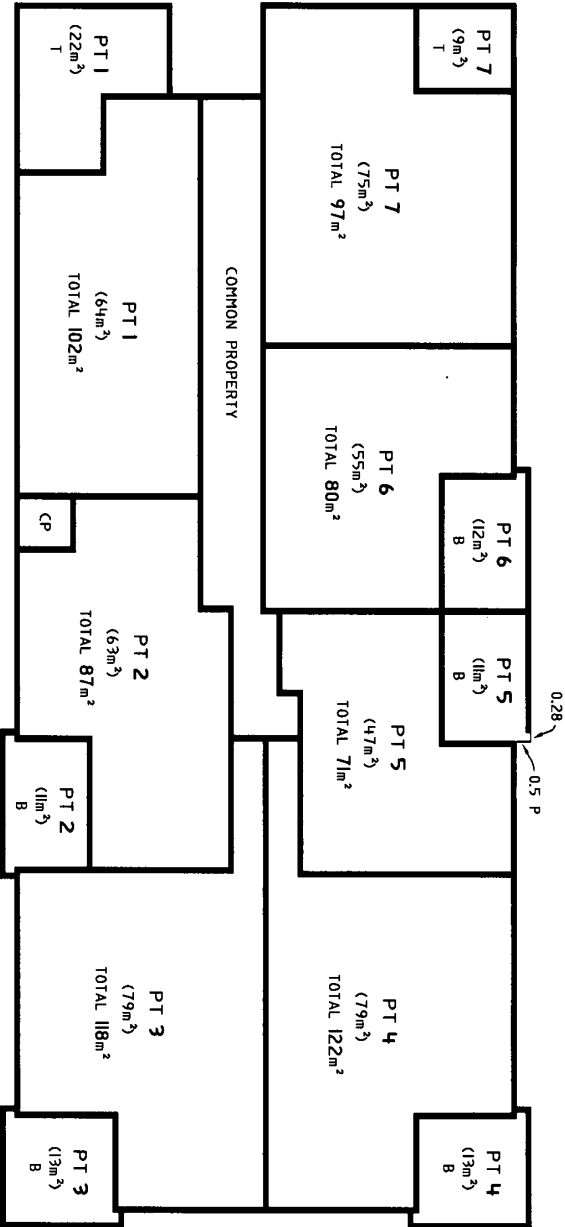

B - DENOTES BALCONY
 T - DENOTES TERRACE
 CP - DENOTES COMMON PROPERTY
 ALL SERVICE DUCTS ARE COMMON PROPERTY
 BALCONIES & TERRACES EXTEND 3 METRES ABOVE THE UPPER SURFACE OF THEIR FLOORS EXCEPT WHERE COVERED.

CAUTION: THE AREAS SHOWN ARE FOR THE PURPOSE OF THE STRATA TITLES ACT ONLY AND ARE APPROXIMATE

10	20	30	40	50	60	70	80	90	100	110	120	130	140
----	----	----	----	----	----	----	----	----	-----	-----	-----	-----	-----

Surveyor: Warren L. Bee
 Surveyor's Ref: 16041SP
 Subdivision No: SC 1167
 Lengths are in metres Reduction Ratio 1:150

Registered
 10.4.2008

SP80483

FIRST FLOOR

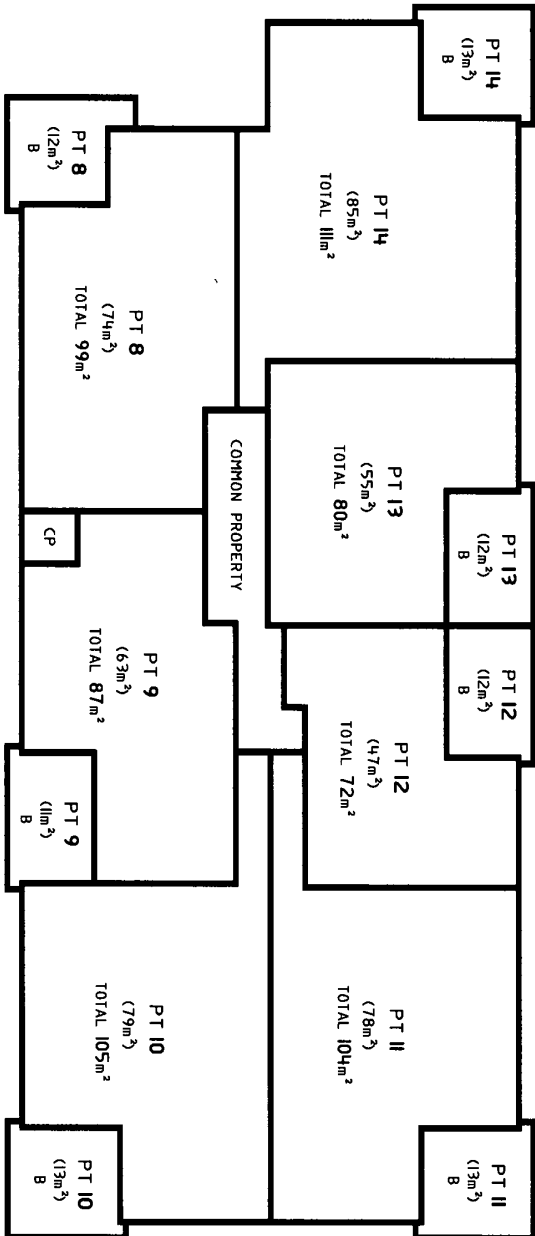

B - DENOTES BALCONY
 CP - DENOTES COMMON PROPERTY
 ALL SERVICE DUCTS ARE COMMON PROPERTY
 BALCONIES EXTEND 3 METRES ABOVE THE UPPER SURFACE OF THEIR FLOORS EXCEPT WHERE COVERED.

CAUTION: THE AREAS SHOWN ARE FOR THE PURPOSE OF THE STRATA TITLES ACT ONLY AND ARE APPROXIMATE

10 20 30 40 50 60 70 80 90 100 110 120 130 140
 Table of mm

Surveyor: Warren L. Bee
 Surveyor's Ref: 1604SP
 Subdivision No: 9C1167
 Lengths are in metres Reduction Ratio 1:150

Registered
 10.4.2008

SP80483

SECOND FLOOR

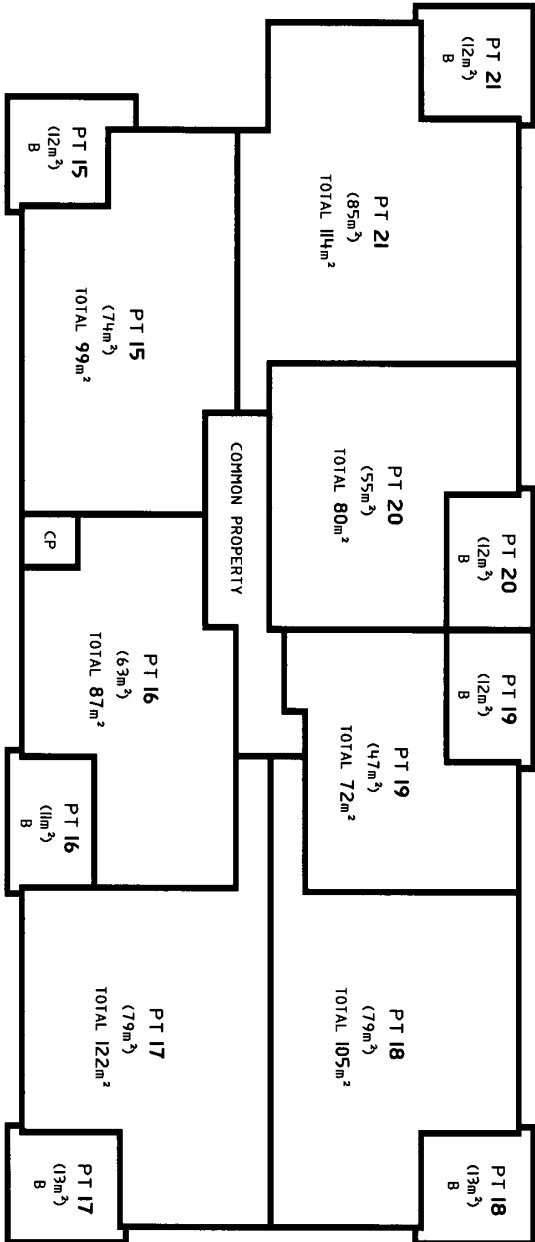

B - DENOTES BALCONY
 CP - DENOTES COMMON PROPERTY
 ALL SERVICE DUCTS ARE COMMON PROPERTY
 BALCONIES EXTEND 3 METRES ABOVE THE
 UPPER SURFACE OF THEIR FLOORS EXCEPT
 WHERE COVERED.

CAUTION: THE AREAS SHOWN ARE FOR THE PURPOSE OF
 THE STRATA TITLES ACT ONLY AND ARE APPROXIMATE

10	20	30	40	50	Table of mm	90	100	110	120	130	140
----	----	----	----	----	-------------	----	-----	-----	-----	-----	-----

Surveyor: Warren L. Bee
 Surveyor's Ref: 16041SP
 Subdivision No: SC 1167
 Lengths are in metres Reduction Ratio 1: 150

Registered
 10.4.2008

SP80483

easing or folding will lead to rejection

STRATA PLAN ADMINISTRATION SHEET

Sheet 1 of 3 sheet(s)

Name of, and address for service of notices on, the Owners Corporation. (Address required on original strata plan only)

The Owners – Strata Plan No 80483

N° 11 – 13 Holborn Avenue
DEE WHY 2099



SP80483 S

Registered: 10.4.2008

Purpose: STRATA PLAN

PLAN OF SUBDIVISION OF LOT 1 in DEPOSITED PLAN 1123703

*Residential Model by-laws adopted for this scheme
 *Keeping of animals: Option B
 *Schedule of By laws in _____ sheets filed with plan
 *No By laws apply
 * strike out whichever is inapplicable

Strata Certificate

* Name of Council/ Accredited Certifier... GORDON WREN
 being satisfied that the requirements of the * Strata Schemes (Freehold Development) Act 1973 ~~or * Strata Schemes (Leasehold Development) Act 1986~~ have been complied with, approves of the proposed:

* strata plan/ ~~strata plan of subdivision~~ illustrated in the annexure to this certificate.

* The accredited certifier is satisfied that the plan is consistent with a relevant development consent in force, and that all conditions of the development consent that by its terms are required to be complied with before a strata certificate may be issued, have been complied with.

~~* The strata plan/strata plan of subdivision is part of a development scheme. The "council"/ accredited certifier is satisfied that the plan is consistent with any applicable conditions of any development consent and that the plan gives effect to the stage of the strata development contract to which it relates.~~

* The Council does not object to the encroachment of the building beyond the alignment of

* The Accredited Certifier is satisfied that the building complies with a relevant development consent in force that allows the encroachment.

* This approval is given on the condition that the use of lot (s).....
(being utility lot) designed to be used primarily for the storage or accommodation of boats, motor vehicles or goods and not for human occupation as a residence, office, shop or the like) is restricted to the proprietor or occupier of a lot or proposed lot (not being such a utility lot) the subject of the strata scheme concerned, as referred to in * section 39 of the Strata Schemes (Freehold Development) Act 1973 or * section 68 of the Strata Schemes (Leasehold Development) Act 1986.

Date... 25 MAR 2008

Subdivision No... SC 1167

Accreditation No... BPB 0447

Relevant Development Consent No... 2007/612

Issued by... WARRINGAH COUNCIL

LGA: Warringah
 Locality: Dee Why
 Parish: Manly Cove
 County: Cumberland

Surveyor's Certificate

I, Warren L Bee
 of PO Box 330, Forestville NSW 2087
 a surveyor registered under the Surveying Act, 2002, hereby certify that:

(1) each applicable requirement of
 *Schedule 1A to the Strata Schemes (Freehold Development) Act 1973
~~*Schedule 1A to the Strata Schemes (Leasehold Development) Act 1986~~
~~has been met;~~

(2) ~~(a) the building encroaches on a public place;~~
~~(b) the building encroaches on land (other than a public place), in respect of which encroachment an appropriate easement~~
~~has been created by registered~~
~~is to be created under section 88B of the Conveyancing Act 1919~~

(3) *the survey information recorded in the accompanying location plan is accurate.

Signature: Warren Bee

Date: 27 February 2008

* Delete if inapplicable
 + State whether dealing or plan, and quote registered number.

SURVEYOR'S REFERENCE: 16041

Use STRATA PLAN FORM 3A for additional certificates, signatures and seals

.....
 Authorised Director / Council Manager / Accredited Certifier
 * Complete or delete if applicable.

* OFFICE USE ONLY

STRATA PLAN ADMINISTRATION SHEET

Sheet 2 of 3 sheet(s)

**PLAN OF SUBDIVISION OF
 LOT 1 in DEPOSITED PLAN 1123703**

SP80483

Registered:  10.4.2008

Strata Certificate Details: Subdivision No: **SC 1167**

Date: **29 MAR 2008**

SCHEDULE OF UNIT ENTITLEMENT
(if insufficient space use additional annexure sheet)

LOT N°	UNIT ENTITLEMENT	LOT N°	UNIT ENTITLEMENT	LOT N°	UNIT ENTITLEMENT
1	53	8	48	15	49
2	55	9	47	16	48
3	58	10	52	17	54
4	58	11	52	18	54
5	41	12	36	19	37
6	36	13	36	20	37
7	50	14	49	21	50
AGGREGATE					1000

Signatures, seals and statements of intention to create easements, restrictions on the use of land or positive covenants
(if insufficient space use additional annexure sheet)

SUNCORP-METWAY Ltd, A.C.N.
 010 831 722 BY ITS ATTORNEY

JOHN ANDREW GARNER

WHO CERTIFIES THAT THEY ARE A
 LEVEL II ATTORNEY PURSUANT
 TO POWER OF ATTORNEY BOOK
 3559 NO. 372 OF WHICH THEY HAVE
 RECEIVED NO NOTICE OF REVOCATION
 SIGNED IN MY PRESENCE BY
 THE SAID ATTORNEY WHO IS
 PERSONALLY KNOWN TO ME

WITNESS

MIKE SERGENT
 1/56 PITT STREET
 SYDNEY NSW 2000

Bellkamen Pty Ltd
 ACN 109 151117
 Sole Director Secretary
 Charles Mchibash

SURVEYOR'S REFERENCE: 16041

* OFFICE USE ONLY

WARNING: Creasing or folding will lead to rejection

STRATA PLAN ADMINISTRATION SHEET		Sheet 3 of 3 sheet(s)
PLAN OF SUBDIVISION OF LOT 1 in DEPOSITED PLAN 1123703	SP80483	*
	Registered:  10.4.2008	*
Strata Certificate Details: Subdivision No: SC 1167		Date: 25 MAR 2008
SURVEYOR'S REFERENCE: 16041		

* OFFICE USE ONLY

MEMORANDUM OF TRANSFER
(REAL PROPERTY ACT, 1906)

Seq: 1 of 2
A899571J

80257

80257

17/12/23
W. G. G. G. G.
17/12/23
W. G. G. G. G.

(Trusts must not be disclosed in the transfer.)

If a less estate, strike out "in fee simple," and interline the required alteration.

A899571

If to two or more, state whether as joint tenants or tenants in common.

If all the references cannot be conveniently inserted, a form of annexure (obtainable at L.T.O.) may be added. Any annexure must be signed by the parties and their signatures witnessed. These references will suffice if the whole land in the grant or certificate be transferred. If part only add "and being lot sec. D.P. being the land shown in the plan annexed hereto," or "being the residue of the land in certificate (or grant) registered Vol. Fol. Where the consent of the local council is required to a subdivision the certificate and plan mentioned in the L. G. Act, 1919, should accompany the transfer.

Strike out if unnecessary. Covenants should comply with section 89 of the Conveyancing Act, 1919. Here also should be set forth any right-of-way or easement or exception. Any provision in addition to or modification of the covenants implied by the Act may also be inserted.

A very short note will suffice.

I, WILLIAM BRAMWELL BOOTH of London England General of the Salvation Army

(herein called transferror)

being registered as the proprietor of an estate in fee simple in the land hereinafter described, subject, however, to such encumbrances, liens and interests as are notified hereunder in consideration of Fifty pounds (£50-0-0) (the receipt whereof is hereby acknowledged) part of which amount was paid by Norman Williams & Sons late of Aburrothunbath (now deceased) and the balance (the receipt whereof is hereby acknowledged) paid to me by

The PUBLIC TRUSTEE in and for the State of New South Wales AND in further consideration of the sum of Eighty pounds (£80) paid to the said Public Trustee (the receipt whereof is hereby acknowledged) by ETHEL MAY BLACKBURN of Dee Why Married Woman (herein called Transferee) do at the request and by the direction of the said Public Trustee testified by his joining in and executing this transfer

do hereby transfer to the transferee ALL such my Estate and Interest in ALL THE land mentioned in the schedule following:—

(c) County.	Parish.	State if Whole or Part.	Vol.	Fol.
Cumberland	Manly Cove	part	2602	195 ✓
and being Lot 8 Section 5 on Deposited Plan 9125.				

And the transferee covenants with the transferror for herself her heirs executors administrators transferees and assigns and so as to bind not only herself but the registered proprietors for the time being of the land hereby transferred doth hereby covenant with the said William Bramwell Booth his heirs executors and administrators that she will not erect or cause to be erected or permit to be erected on the land hereby transferred any house which shall be of a value of less then One hundred pounds AND FURTHER that she will not sell or permit to be sold or connive at or be a party to the sale of any wines beers ales spirits or any other intoxicating liquor of any kind whatsoever on the said land AND FURTHER that she will not carry on or permit to be carried on upon the said land or any part thereof any noxious noisome or offensive trade occupation or business. AND FURTHER that she will not erect in respect of the land hereby transferred any dividing fence without the consent of the said William Bramwell Booth provided that such consent shall be withheld if such fence or fences be erected without expense to the said William Bramwell Booth. The land to which this covenant is intended to be appurtenant is the residue of the land comprised in the said Deposited Plan and the land which is to be subject to the burden hereof is the land hereby transferred and the person by whom and with whose consent this covenant may be released varied or modified is the abovenamed William Bramwell Booth his heirs executors or administrators or Attorney or other the General for the time being of the Salvation Army his heirs executors or administrators or ENCUMBRANCES, &c., REFERRED TO.

Subject to such notifications and easements (if any) as

appear on the said Certificate of Title and the said Deposited plan.

Signed at Sydney the twenty eighth day of December 19 22
HUGH EDWARD WHATMORE (as the duly constituted Attorney of WILLIAM BRAMWELL BOOTH) WHO IS PERSONALLY KNOWN TO ME

[Signature]
Transferror's Attorney

[Signature]
Signed and sealed by the Public Trustee who is personally known to me
M. H. Lowe
Commissioner for Affidavits

Witness
PUBLIC TRUSTEE

Accepted, and I hereby certify this Transfer to be correct for the purposes of the Real Property Act.

Signed in my presence by the transferee
WHO IS PERSONALLY KNOWN TO ME
[Signature]
Solicitor

[Signature]
Transferee.

* If signed by virtue of any power of attorney, the original must be registered, and an attested copy deposited, and the memorandum of non-revocation on page 2 signed by the attorney before a witness.

† N.B.—Section 117 requires that the above Certificate be signed by Transferee or his Solicitor, and renders any person falsely or negligently certifying liable to a penalty of £50; also to damages recoverable by parties injured. If the Solicitor signs he must sign his own name and not that of his firm.

I, *release and discharge the land comprised in the within transfer from such mortgage and all claims thereunder but without prejudice to my rights and remedies as regards the balance of the land comprised in such mortgage.*

Dated at *this* *1923* day of *December*
 Signed in my presence by *[Signature]*
 who is personally known to me.

mortgagee under Mortgage No. _____
 Mortgagor.
 Mortgagee.

A 899571

MEMORANDUM AS TO NON-REVOCATION OF POWER OF ATTORNEY.
 (To be signed at the time of executing the within instrument.)

Memorandum whereby the undersigned states that he has no notice of the revocation of the Power of Attorney registered No. *1082* Miscellaneous Register under the authority of which he has just executed the within transfer.

Signed at *Sydney* the *twenty eighth* day of *December* 192*3*.
 Signed at the place and on the date above-mentioned, in the presence of—
[Signature]

FORM OF DECLARATION BY ATTESTING WITNESS.

Appeared before me at _____, the _____ day of _____, one thousand nine hundred and twenty _____, the attesting witness to this instrument, and declared that he personally knew _____ the person signing the same, and whose signature thereto he has attested; and that the name purporting to be such signature of the said _____ is _____ own handwriting, and that he was of sound mind and freely and voluntarily signed the same.

h Strike out unnecessary words. Add any other matter necessary to show that the power is effective.

i May be made before either Registrar-General, Deputy Registrar-General, a Notary Public, J.P., or Commissioner for Affidavits. Not required if the instrument itself be made or acknowledged before one of these parties.

MEMORANDUM OF TRANSFER of _____
 Acres _____ roods _____ perches.
Lot 8 Sec. 5 D.P. 9125
at Deewy
 Shire *Harrington*
 Municipality _____
 Parish *Manly Cove* County *Cumberland*
 Subject to covenant
Ethel May Blackburn Transferee.

LODGED BY
[Signature]

Particulars entered in Register Book, Vol *7602* Fol. *195*

DOCUMENTS LODGED HEREWITH.
 To be filled in by person lodging dealing.

Nature.	No.	Reg'd Propr., M't'gor, etc.

the *30th* day of *January* 192*3*,
 at _____ minutes *3* o'clock in the *afternoon*.



PROGRESS RECORD.

Sent to Survey Branch ...	<i>[Signature]</i> <i>18/1/23</i>	
Received from Records ...	<i>[Signature]</i> <i>do</i>	<i>19</i>
Draft written ...	<i>[Signature]</i> <i>19/1/23</i>	
Draft examined ...	<i>[Signature]</i> <i>21/1/23</i>	
Diagram prepared ...	<i>[Signature]</i> <i>23/1/23</i>	
Diagram examined ...	<i>[Signature]</i> <i>29/1/23</i>	
Draft forwarded ...	<i>[Signature]</i> <i>29/1/23</i>	
Supt. of Engrossers ...	<i>[Signature]</i> <i>2 FEB 1923</i>	
Cancellation Clerk ...	<i>[Signature]</i>	

If the parties be resident without the State, but in any other part of the British Dominions, the instrument must be signed or acknowledged before the Registrar-General or Recorder of Titles of such Possession, or before any Judge, Notary Public, Justice of the Peace for New South Wales, or Commissioner for taking affidavits for New South Wales, or the Mayor or Chief Officer of any municipal or local government corporation of such part, or the Governor, Government Resident, or Chief Secretary of such part or such other person as the Chief Justice of New South Wales may appoint.

If resident in the United Kingdom, then before the Mayor or Chief Officer of any corporation or a Notary Public.

If resident at any foreign place, then the parties should sign or acknowledge before a British Minister, Ambassador, Envoy, Minister Chargé d'Affaires, Secretary of the Embassy or Legation, Consul-General, Consul, Vice-Consul, Acting Consul, Pro-consul or Consular Agent, who should affix his seal of office, or the attesting witness may make a declaration of the due execution thereof before one of such persons (who should sign and affix his seal to such declaration), or such other person as the said Chief Justice may appoint.

The fees are:—Registration fee 12/6 for endorsement on first certificate, and 2/6 for each additional certificate included in the Transfer, and £1 5s. for every new Certificate of Title issued. Additional Certificate fees, however, may be necessary in cases involving more than a simple diagram or more than six folios of engrossing.

Tenants in common must receive separate Certificates.

If part only of the land is transferred a new Certificate must issue, but the old Certificate may remain in the Office or the Transferor may take out a new Certificate for the residue.

CHECK SLIP.

296267
97910
1083

Robson & Cowlshaw
 6880 1215

No. **A937452** CONSENT OF MORTGAGEE.

release and discharge the land comprised in the mortgage under Mortgage No. _____ hereunder but without prejudice to my rights and remedies as regards the balance of the land comprised in such mortgage.

Dated at _____ this _____ day of _____ 192____ }
 Signed in my presence by _____ }
 who is personally known to me. } Mortgagee.

MEMORANDUM AS TO NON-REVOCATION OF POWER OF ATTORNEY.
 (To be signed at the time of executing the within instrument.)

Memorandum whereby the undersigned states that he has no notice of the revocation of the Power of Attorney registered No. 1082 Miscellaneous Register under the authority of which he has just executed the within transfer.

Signed at Sydney the thirteenth day of April 1923.
 Signed at the place and on the date above-mentioned, in the presence of—
W. J. Weddall

Strike out unnecessary words. Add any other matter necessary to show that the power is effective.

FORM OF DECLARATION BY ATTESTING WITNESS.

Appeared before me at _____, the _____ day of _____, one thousand nine hundred and twenty _____, the attesting witness to this instrument, and declared that he personally knew _____ the person signing the same, and whose signature thereto he has attested; and that the name purporting to be such signature of the said _____ is _____ own handwriting, and that he was of sound mind and freely and voluntarily signed the same.

May be made before either Registrar-General, Deputy Registrar-General, a Notary Public, J.P., or Commissioner for Affidavits. Not required if the instrument itself be made or acknowledged before one of these parties.

MEMORANDUM OF TRANSFER of _____

Acres _____ roods _____ perches.
Lot 9 Sub 5. BP 9135.
 near Long Reef
 Shire of Warringah
 Parish _____ County _____
Elysa Louise Aker Transferee.

LODGED BY

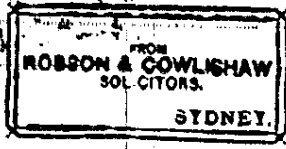

Particulars entered in Register Book, Vol. 262 Fol. 195.

DOCUMENTS LODGED HEREWITH.
 To be filled in by person lodging dealing.

Nature.	No.	Reg'd Propr. M'gor, etc.

the _____ day of May 1923
 at _____ minutes past _____ o'clock in the _____
W. J. Weddall
 Registrar General

PROGRESS RECORD.

	Initials.	Date.
Sent to Survey Branch ...	<u>WJW</u>	<u>7-5-23</u>
Received from Records ...	<u>WJW</u>	<u>7-5-23</u>
Draft written ...	<u>WJW</u>	<u>7-5-23</u>
Draft examined ...	<u>WJW</u>	<u>7-5-23</u>
Diagram prepared ...	<u>WJW</u>	<u>7-5-23</u>
Diagram examined ...	<u>WJW</u>	<u>7-5-23</u>
Draft forwarded ...	<u>WJW</u>	<u>7-5-23</u>
Supt. of Engrossers ...	<u>WJW</u>	<u>7-5-23</u>
Cancellation Clerk ...	<u>WJW</u>	<u>7-5-23</u>
Vol. <u>3450</u> Fol. <u>96</u>		
Diagram Fees ...	<u>3/</u>	<u>0/4</u>
Additional Folios ...	<u>3/</u>	<u>0/4</u>

If the parties be resident without the State, but in any other part of the British Dominions, the instrument must be signed or acknowledged before the Registrar-General or Recorder of Titles of such Possession, or before any Judge, Notary Public, Justice of the Peace for New South Wales, or Commissioner for taking affidavits for New South Wales, or the Mayor or Chief Officer of any municipal or local government corporation of such part, or the Governor, Government Resident, or Chief Secretary of such part or such other person as the Chief Justice of New South Wales may appoint.

If resident in the United Kingdom then before the Mayor or Chief Officer of any corporation or a Notary Public.

If resident at any foreign place, then the parties should sign or acknowledge before a British Minister, Ambassador, Envoy, Minister Charge d'Affaires, Secretary of the Embassy or Legation, Consul-General, Consul, Vice-Consul, Acting Consul, Pro-Consul or Consular Agent, who should affix his seal or office, or the attesting witness may make a declaration of the due execution thereof before one of such persons (who should sign and affix his seal to such declaration), or such other person as the said Chief Justice may appoint.

The fees are:—Registration fee 12/6 for endorsement on first certificate, and 2/6 for each additional certificate included in the Transfer, and 1/6 for every new Certificate of Title issued. Additional Certificate fees, however, may be necessary in cases involving more than a simple diagram or more than six folios of engrossing.

Tenants in common must receive separate Certificates.
 If part only of the land is transferred a new Certificate must issue, but the old Certificate may remain in the office or the Transferee may take out a new Certificate for the residue.

DEPOSITED PLAN ADMINISTRATION SHEET

Sheet 1 of 2 sheet(s)

SIGNATURES, SEALS and STATEMENTS of intention to dedicate public roads, to create public reserves, drainage reserves, easements, restrictions on the use of land or positive covenants.

Pursuant to Section 88b of the Conveyancing Act 1919 it is intended to create:

- 1. Easement to Drain Water 1 wide



DP1123703 S

Registered: 7.3.2008
 Title System: TORRENS
 Purpose: CONSOLIDATION



* OFFICE USE ONLY

PLAN OF Consolidation of Lots 8 & 9
 Section 5 in Deposited Plan 9125 &
 Easement to Drain Water 1 wide in Strata Plan 5089

LGA: Warringah
 Locality: Dee Why
 Parish: Manly Cove
 County: Cumberland

Surveying Regulation, 2006

I, ...Warren Lewelyn Bee
 of .PO Box 330 Forestville 2087

a surveyor registered under the *Surveying Act, 2002*, certify that the survey represented in this plan is accurate, has been made in accordance with the *Surveying Regulation, 2006* and was completed on...30th November 2007

The survey relates to Lot 1 & Easement to Drain Water

(specify the land actually surveyed or specify any land shown in the plan that is not the subject of the survey)

Signature *Warren Bee* Dated: *30/11/2007*
 Surveyor registered under the *Surveying Act, 2002*

Datum Line: "X" - "Y"
 Type: *Urban*

Plans used in the preparation of survey

- 9125
- 879342
- 1065495
- 1043690
- 1010339
- 1107687
- 856400

(if insufficient space use Plan Form 6A annexure sheet)

SURVEYOR'S REFERENCE: 16041

Use PLAN FORM 6A

for additional certificates, signatures, seals and statements

Crown Lands NSW/Western Lands Office Approval

I.....in approving this plan certify
 (Authorised Officer)
 that all necessary approvals in regard to the allocation of the land shown herein have been given

Signature:.....
 Date:.....
 File Number:.....
 Office:.....

Subdivision Certificate

I certify that the provisions of s.109J of the Environmental Planning and Assessment Act 1979 have been satisfied in relation to:

the proposed..... set out herein
 (insert 'subdivision' or 'new road')

* Authorised Person/General Manager/Accredited Certifier

Consent Authority:
 Date of Endorsement:
 Accreditation no:
 Subdivision Certificate no:
 File no:

* Delete whichever is inapplicable.

DEPOSITED PLAN ADMINISTRATION SHEET

Sheet 2 of 2 sheet(s)

PLAN OF Consolidation of Lots 8 & 9
 Section 5 in Deposited Plan 9125 &
 Easement to Drain Water 1 wide in Strata Plan 5089

DP1123703

Registered: 7.3.2008



JS

* OFFICE USE ONLY

Subdivision Certificate No:

Date of Endorsement:

The Common Seal of the owners of
 Strata Plan 5089 was affixed hereto
 on the 15th day of February 2008
 in the presence of:



[Handwritten signature]

SUNCORP METWAY Ltd A.C.N.
 010 831 722 BY ITS ATTORNEY
 KENNETH HARDING SEETO
 WHO CERTIFIES THAT THEY ARE A
 LEVEL II ATTORNEY PURSUANT
 TO POWER OF ATTORNEY BOOK
 3859 NO. 372 OF WHICH THEY HAVE
 RECEIVED NO NOTICE OF
 REVOCATION

KH

SIGNED IN MY PRESENCE BY
 THE SAID ATTORNEY WHO IS
 PERSONALLY KNOWN TO ME
 MIKE SERGENT
 LEVEL 1, 56 PITT ST, SYDNEY NSW

WITNESS

MS

BELL CONNOR Pty Limited
 CHARLES VICTOR MCINTOSH
 SOLA DIRECTOR (Sydney)

[Handwritten signature]
 ABN: 58 109 15 117

PETER DALY for
 mason & BROWN STRATA MANAGEMENT P/L.

Being the person(s) authorised
 by section 238 Strata Schemes
 Management Act 1996 to attest to
 the affixing of the seal.

**INSTRUMENT SETTING OUT TERMS OF EASEMENTS INTENDED TO BE CREATED
PURSUANT TO SECTION 88B OF THE CONVEYANCING ACT 1919.**

Lengths are in metres

Sheet 1 of 3 sheets



DP1123703 B

**Full name and address
of proprietors of land:**

Plan of Consolidation of Lots 8 & 9 Section
5 in Deposited Plan 9125 & Easement to
Drain Water 1 wide in Strata Plan 5089.

Registered Proprietors

The Owners (Common Property)
Strata Plan N° 5089
14 Lismore Avenue
Dee Why NSW 2099

Ian Scott Harris
(Lot 1 Strata Plan N° 5089)
1/14 Lismore Avenue
Dee Why NSW 2099

PART 1 (CREATION)

Number of item shown in the intention panel of the plan	Identity of easement, profit à prendre, restriction or positive covenant to be created and referred to in the plan	Burdened lot(s) or parcel(s)	Benefited lot(s), road(s), bodies or Prescribed Authorities
1	Easement to Drain Water 1.0 wide	CP/5089 1/SP 5089	1



Scott Harris

[Signature]

[Signature]

Sheet 2 of 3 sheets

DP1123703

Plan of Consolidation of Lots 8 & 9 Section 5 in Deposited Plan 9125 & Easement to Drain Water 1 wide in Strata Plan 5089.

EXECUTION



Executed by Registered Proprietor (common property) The Owners Strata Plan N° 5089
The Common Seal of The Owners - Strata Plan 5089 was affixed
on the 15th day of February 2008 in the presence of:

[Handwritten signature]
.....

Peter Day for Masud & Brogan
Name (BLOCK LETTERS) *Masud & Brogan Pty* Name (BLOCK LETTERS)
Being the person(s) authorised by Section 238
Strata Schemes Management Act 1996 to attest
to the affixing of the seal.

Signed in my presence by Mr Ian Scott Harris
who is personally known to me.

.....
SIGNATURE OF WITNESS

[Handwritten signature: Mark McJanna]
.....
NAME OF WITNESS (block letters)

[Handwritten signature: Scott Harris]

1 Oaks Ave
.....
Dee Why NSW 2099, Solicitor.
.....
ADDRESS AND OCCUPATION OF WITNESS.

[Handwritten signature]
BELLGONGHALL Pty Limited
CIVIL & VICTOR MCINTOSH
Sole Director / Secretary
ABN: 58109151117

DP1123703

Plan of Consolidation of Lots 8 & 9 Section
5 in Deposited Plan 9125 & Easement to
Drain Water 1 wide in Strata Plan 5089.

MORTGAGEE CONSENT

SUNCORP METWAY Ltd A.C.N.
010 831 722 BY ITS ATTORNEY
KENNETH HARDING SEETO
WHO CERTIFIES THAT THEY ARE A
LEVEL II ATTORNEY PURSUANT
TO POWER OF ATTORNEY BOOK
3859 NO. 372 OF WHICH THEY HAVE
RECEIVED NO NOTICE OF
REVOCAION

KH

MM

WITNESS

SIGNED IN MY PRESENCE BY
THE SAID ATTORNEY WHO IS
PERSONALLY KNOWN TO ME

MIKE SERGENT
LEVEL 1, 56 PITT ST, SYDNEY NSW

REGISTERED  7.3.2008



AN95862E

Form: 15CH
Release: 2-1

**CONSOLIDATION/
CHANGE OF BY-LAWS**
New South Wales
Strata Schemes Management Act 2015
Real Property Act 1900

PRIVACY NOTE: Section 31B of the Real Property Act 1900 (RP Act) authorises the Registrar General to collect the information required by this form for the establishment and maintenance of the Real Property Act Register. Section 96B RP Act requires that the Register is made available to any person for search upon payment of a fee, if any.

(A) TORRENS TITLE	For the common property CP/SP 80483			
	(B) LODGED BY	<table border="1"> <tr> <td>Document Collection Box <i>1W</i></td> <td>Name, Address or DX, Telephone, and Customer Account Number if any LAMB AND WALTERS PO BOX 95, GORDON, NSW, 2072 (02) 9449 8855 Reference: _____</td> <td>CODE CH</td> </tr> </table>	Document Collection Box <i>1W</i>	Name, Address or DX, Telephone, and Customer Account Number if any LAMB AND WALTERS PO BOX 95, GORDON, NSW, 2072 (02) 9449 8855 Reference: _____
Document Collection Box <i>1W</i>	Name, Address or DX, Telephone, and Customer Account Number if any LAMB AND WALTERS PO BOX 95, GORDON, NSW, 2072 (02) 9449 8855 Reference: _____	CODE CH		

- (C) The Owners-Strata Plan No. 80483 certify that a special resolution was passed on 28/8/2017
- (D) pursuant to the requirements of section 141 of the Strata Schemes Management Act 2015, by which the by-laws were changed as follows—
- (E) Repealed by-law No. Model By-Laws 1-20
 Added by-law No. Model By-Laws 1-19 & Special By-Law 4
 Amended by-law No. NOT APPLICABLE
 as fully set out below:
 Annexure A

- (F) A consolidated list of by-laws affecting the above mentioned strata scheme and incorporating the change referred to at Note (E) is annexed hereto and marked as Annexure A
- (G) The seal of The Owners-Strata Plan No. 80483 was affixed on 8/1/2018 in the presence of the following person(s) authorised by section 273 Strata Schemes Management Act 2015 to attest the affixing of the seal:

Signature: *[Signature]*
 Name: TALOFA POULI
 Authority: STRATA MANAGER
 Signature: _____
 Name: _____
 Authority: _____

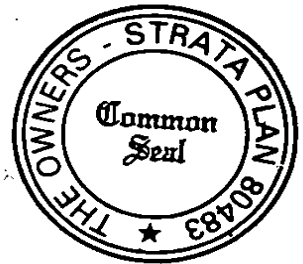

1 Vehicles

An owner or occupier of a lot must not park or stand any motor or other vehicle on common property, or permit a motor vehicle to be parked or stood on common property, except with the prior written approval of the owners corporation or as permitted by a sign authorised by the owners corporation.

2 Changes to common property

(1) An owner or person authorised by an owner may install, without the consent of the owners corporation:

(a) any locking or other safety device for protection of the owner's lot against intruders or to improve safety within the owner's lot, or

(b) any screen or other device to prevent entry of animals or insects on the lot, or

(c) any structure or device to prevent harm to children.

(2) Any such locking or safety device, screen, other device or structure must be installed in a competent and proper manner and must have an appearance, after it has been installed, in keeping with the appearance of the rest of the building.

(3) Clause (1) does not apply to the installation of any thing that is likely to affect the operation of fire safety devices in the lot or to reduce the level of safety in the lots or common property.

(4) The owner of a lot must:

(a) maintain and keep in a state of good and serviceable repair any installation or structure referred to in clause (1) that forms part of the common property and that services the lot, and

(b) repair any damage caused to any part of the common property by the installation or removal of any locking or safety device, screen, other device or structure referred to in clause (1) that forms part of the common property and that services the lot.

3 Damage to lawns and plants on common property

An owner or occupier of a lot must not, except with the prior written approval of the owners corporation:

(a) damage any lawn, garden, tree, shrub, plant or flower being part of or situated on common property, or

(b) use for his or her own purposes as a garden any portion of the common property.

4 Obstruction of common property

An owner or occupier of a lot must not obstruct lawful use of common property by any person except on a temporary and non-recurring basis.

This is page ___ of a total of 25 and is the annexure to the Consolidation/Change of By-Laws form by The Owners – Strata Plan No. 80483

THE SEAL of THE OWNERS – STRATA PLAN NO. 80483 was affixed on the 8th day of January 2018 in the presence of the following person(s) authorised by Section 273 of the Strata Schemes Management Act 2015 to attest the affixing of the seal.

Signature: _____

Name(s): TALOFA POULI _____

Authority: STRATA MANAGER _____



5 Keeping of animals

(1) An owner or occupier of a lot may keep an animal on the lot, if the owner or occupier gives the owners corporation written notice that it is being kept on the lot.

(2) The notice must be given not later than 14 days after the animal commences to be kept on the lot.

(3) If an owner or occupier of a lot keeps an animal on the lot, the owner or occupier must:

(a) keep the animal within the lot, and

(b) supervise the animal when it is on the common property, and

(c) take any action that is necessary to clean all areas of the lot or the common property that are soiled by the animal.

6 Noise

An owner or occupier of a lot, or any invitee of an owner or occupier of a lot, must not create any noise on a lot or the common property likely to interfere with the peaceful enjoyment of the owner or occupier of another lot or of any person lawfully using common property.

7 Behaviour of owners, occupiers and invitees

(1) An owner or occupier of a lot, or any invitee of an owner or occupier of a lot, when on common property must be adequately clothed and must not use language or behave in a manner likely to cause offence or embarrassment to the owner or occupier of another lot or to any person lawfully using common property.

(2) An owner or occupier of a lot must take all reasonable steps to ensure that invitees of the owner or occupier:

(a) do not behave in a manner likely to interfere with the peaceful enjoyment of the owner or occupier of another lot or any person lawfully using common property, and

(b) without limiting paragraph (a), that invitees comply with clause (1).

8 Children playing on common property

(1) Any child for whom an owner or occupier of a lot is responsible may play on any area of the common property that is designated by the owners corporation for that purpose but may only use an area designated for swimming while under adult supervision.

(2) An owner or occupier of a lot must not permit any child for whom the owner or occupier is responsible, unless accompanied by an adult exercising effective control, to be or remain on common property that is a laundry, car parking area or other area of possible danger or hazard to children.

9 Smoke penetration

(1) An owner or occupier, and any invitee of the owner or occupier, must not smoke tobacco or any other substance on the common property.

This is page __ of a total of 25 and is the annexure to the Consolidation/Change of By-Laws form by The Owners – Strata Plan No. 80483

THE SEAL of THE OWNERS – STRATA PLAN NO. 80483 was affixed on the 8th day of January 2018 in the presence of the following person(s) authorised by Section 273 of the Strata Schemes Management Act 2015 to attest the affixing of the seal.

Signature: _____

Name(s): TALOFA POULI _____

Authority: STRATA MANAGER _____

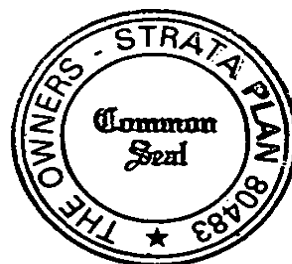

(2) An owner or occupier of a lot must ensure that smoke caused by the smoking of tobacco or any other substance by the owner or occupier, or any invitee of the owner or occupier, on the lot does not penetrate to the common property or any other lot.

10 Preservation of fire safety

The owner or occupier of a lot must not do any thing or permit any invitees of the owner or occupier to do any thing on the lot or common property that is likely to affect the operation of fire safety devices in the parcel or to reduce the level of fire safety in the lots or common property.

11 Storage of inflammable liquids and other substances and materials

(1) An owner or occupier of a lot must not, except with the prior written approval of the owners corporation, use or store on the lot or on the common property any inflammable chemical, liquid or gas or other inflammable material.

(2) This by-law does not apply to chemicals, liquids, gases or other material used or intended to be used for domestic purposes, or any chemical, liquid, gas or other material in a fuel tank of a motor vehicle or internal combustion engine.

12 Appearance of lot

(1) The owner or occupier of a lot must not, without the prior written approval of the owners corporation, maintain within the lot anything visible from outside the lot that, viewed from outside the lot, is not in keeping with the rest of the building.

(2) This by-law does not apply to the hanging of any clothing, towel, bedding or other article of a similar type in accordance with by-law 14.

13 Cleaning windows and doors

(1) Except in the circumstances referred to in clause (2), an owner or occupier of a lot is responsible for cleaning all interior and exterior surfaces of glass in windows and doors on the boundary of the lot, including so much as is common property.

(2) The owners corporation is responsible for cleaning regularly all exterior surfaces of glass in windows and doors that cannot be accessed by the owner or occupier of the lot safely or at all.

14 Hanging out of washing

(1) An owner or occupier of a lot may hang any washing on any lines provided by the owners corporation for that purpose. The washing may only be hung for a reasonable period.

(2) An owner or occupier of a lot may hang washing on any part of the lot other than over the balcony railings. The washing may only be hung for a reasonable period.

This is page ___ of a total of 25 and is the annexure to the Consolidation/Change of By-Laws form by The Owners – Strata Plan No. 80483

THE SEAL of THE OWNERS – STRATA PLAN NO. 80483 was affixed on the 8th day of January 2018 in the presence of the following person(s) authorised by Section 273 of the Strata Schemes Management Act 2015 to attest the affixing of the seal.

Signature: _____

Name(s): TALOFA POULI _____

Authority: STRATA MANAGER _____



(3) In this by-law:

"washing" includes any clothing, towel, bedding or other article of a similar type.

15 Disposal of waste-bins for individual lots [applicable where individual lots have bins]

(1) An owner or occupier of a lot must not deposit or throw on the common property any rubbish, dirt, dust or other material or discarded item except with the prior written approval of the owners corporation.

(2) An owner or occupier of a lot must not deposit in a toilet, or otherwise introduce or attempt to introduce into the plumbing system, any item that is not appropriate for any such disposal (for example, a disposable nappy).

(3) An owner or occupier must:

(a) comply with all reasonable directions given by the owners corporation as to the disposal and storage of waste (including the cleaning up of spilled waste) on common property, and

(b) comply with the local council's guidelines for the storage, handling, collection and disposal of waste.

(4) An owner or occupier of a lot must maintain bins for waste within the lot, or on any part of the common property that is authorised by the owners corporation, in clean and dry condition and appropriately covered.

(5) An owner or occupier of a lot must not place any thing in the bins of the owner or occupier of any other lot except with the permission of that owner or occupier.

(6) An owner or occupier of a lot must place the bins within an area designated for collection by the owners corporation not more than 12 hours before the time at which waste is normally collected and, when the waste has been collected, must promptly return the bins to the lot or other area authorised for the bins.

(7) An owner or occupier of a lot must notify the local council of any loss of, or damage to, bins provided by the local council for waste.

(8) The owners corporation may give directions for the purposes of this by-law by posting signs on the common property with instructions on the handling of waste that are consistent with the local council's requirements or giving notices in writing to owners or occupiers of lots.

(9) In this by-law:

"bin" includes any receptacle for waste.

"waste" includes garbage and recyclable material.

16 Disposal of waste-shared bins [applicable where bins are shared by lots]

(1) An owner or occupier of a lot must not deposit or throw on the common property any rubbish, dirt, dust or other material or discarded item except with the prior written approval of the owners corporation.

(2) An owner or occupier of a lot must not deposit in a toilet, or otherwise introduce or attempt to introduce into the plumbing system, any item that is not appropriate for any such disposal (for example, a disposable nappy).

This is page ___ of a total of 25 and is the annexure to the Consolidation/Change of By-Laws form by The Owners – Strata Plan No. 80483

THE SEAL of THE OWNERS – STRATA PLAN NO. 80483 was affixed on the 8th day of January 2018 in the presence of the following person(s) authorised by Section 273 of the Strata Schemes Management Act 2015 to attest the affixing of the seal.

Signature: _____

Name(s): TALOFA POULI _____

Authority: STRATA MANAGER _____

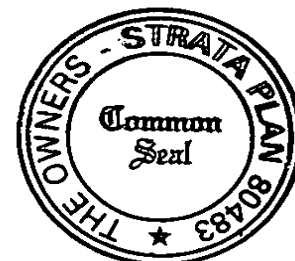

(3) An owner or occupier must:

- (a) comply with all reasonable directions given by the owners corporation as to the disposal and storage of waste (including the cleaning up of spilled waste) on common property, and
- (b) comply with the local council's guidelines for the storage, handling, collection and disposal of waste.

(4) The owners corporation may give directions for the purposes of this by-law by posting signs on the common property with instructions on the handling of waste that are consistent with the local council's requirements or giving notices in writing to owners or occupiers of lots.

(5) In this by-law:

"bin" includes any receptacle for waste.

"waste" includes garbage and recyclable material.

17 Change in use or occupation of lot to be notified

(1) An occupier of a lot must notify the owners corporation if the occupier changes the existing use of the lot.

(2) Without limiting clause (1), the following changes of use must be notified:

- (a) a change that may affect the insurance premiums for the strata scheme (for example, if the change of use results in a hazardous activity being carried out on the lot, or results in the lot being used for commercial or industrial purposes rather than residential purposes),
- (b) a change to the use of a lot for short-term or holiday letting.

(3) The notice must be given in writing at least 21 days before the change occurs or a lease or sublease commences.

18 Compliance with planning and other requirements

(1) The owner or occupier of a lot must ensure that the lot is not used for any purpose that is prohibited by law.

(2) The owner or occupier of a lot must ensure that the lot is not occupied by more persons than are allowed by law to occupy the lot.

Special by law 1: Exclusive Use of Courtyard Area/Garden

- a. Resolve that the owner or occupier from the time being of lots 1-5 in Strata Plan 80483 shall be entitled to the exclusive use and enjoyment of the courtyard/ garden area shown on the plan annexed hereto and marked "A" (the Exclusive Use Area) and as designated for

This is page ___ of a total of 25 and is the annexure to the Consolidation/Change of By-Laws form by The Owners – Strata Plan No. 80483

THE SEAL of THE OWNERS – STRATA PLAN NO. 80483 was affixed on the 8th day of January 2018 in the presence of the following person(s) authorised by Section 273 of the Strata Schemes Management Act 2015 to attest the affixing of the seal.

Signature: _____

Name(s): TALOFA POULI _____

Authority: STRATA MANAGER _____

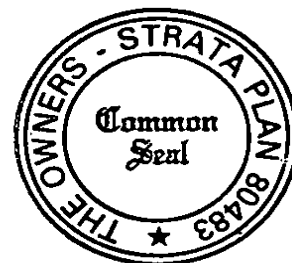

each respective lot in the schedule to this by-law, for any lawful purpose including without limitation a special privilege to use that area on the following conditions; -

- (a) The owner and occupier shall be responsible for the proper maintenance and keep in a state of good and serviceable repair of the common property in respect of which exclusive use is hereby granted.
- (b) The owner and occupier shall be responsible to maintain and keep in a state of good and serviceable repair the exclusive use area including any alteration and additions undertaken pursuant to this by-law and shall perform maintenance or repair upon or replace the alterations and additions when the Owners Corporation by written notice shall require the owner or occupier to do so in a manner approved by or directed by the Owners Corporation in writing (though not in a manner substantially inconsistent with the alteration and additions).

If the owners or the occupier does not maintain and keep in a state of good and serviceable repair the exclusive use area to the satisfaction of the Owner Corporation, then without any notice the Owners Corporation may do any work or maintenance that it considers necessary and charge the owner or the occupier for the cost of such work or repairs.

- (c) The owner and the occupier shall indemnify and keep indemnified the Owners Corporation against: -
 - I. Any sums payable by the Owners Corporation by way of increase premiums as a direct or indirect result of the right to exclusive use of the relevant area of common property;
 - II. All actions, proceedings, claims and demands, cost, damages and expenses which may be incurred by or brought or made against the Owners Corporation and arising directly or indirectly out of the works all or the altered state of the common property or lots arising therefrom;

This is page ___ of a total of 25 and is the annexure to the Consolidation/Change of By-Laws form by The Owners – Strata Plan No. 80483

THE SEAL of THE OWNERS – STRATA PLAN NO. 80483 was affixed on the 8th day of January 2018 in the presence of the following person(s) authorised by Section 273 of the Strata Schemes Management Act 2015 to attest the affixing of the seal.

Signature: _____

Name(s): TALOFA POULI _____

Authority: STRATA MANAGER _____

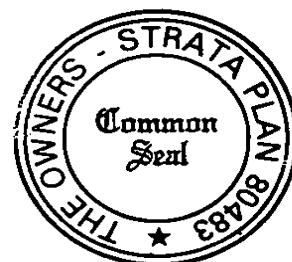

- iii. All costs, including legal costs, for making of this by-law; and any liability on the part of the owners corporation for any damage to works or improvements caused by or arising out of the carrying work referred to in Section 54 in the Strata Schemes Management Act, 1996, or the exercise of the power of entry conferred by that section;
- (d) Any damage to the common property in the Strata Scheme caused directly or indirectly by the works or by the altered conditions on the common property or lots arising from the works shall be made good by and at the cost of the owners or occupier:
- (e) The work shall be done in a proper and workmanlike manner and by qualified tradesman:
- (f) Where the owner or the occupier fails or neglect to carry out any work and discharge any duty referred to herein, the Owners Corporation by it's agents, servants or contractors may carry out such work or perform such duty and may enter upon any part of the parcel for this purpose at any reasonable time or on notice given to any occupier of that part of the parcel, and may recover the cost of doing such work or duty as a debt from the owner or occupier;
- (g) Any reference in Clause 1 to the owner and/or the occupier of the lot which has benefit of the use of a courtyard/garden area, shall apply as to any act, liability or requirement imposed on them in on a joint and several basis;
- (h) The benefit of the use of a courtyard/garden area that forms part of the common property is subject to any easements or rights of way that have been created or are to be created as part of the original constructions of the buildings and the registration of the Strata Plan, including for water drainage and electricity.

This is page ___ of a total of 25 and is the annexure to the Consolidation/Change of By-Laws form by The Owners – Strata Plan No. 80483

THE SEAL of THE OWNERS – STRATA PLAN NO. 80483 was affixed on the 8th day of January 2018 in the presence of the following person(s) authorised by Section 273 of the Strata Schemes Management Act 2015 to attest the affixing of the seal.

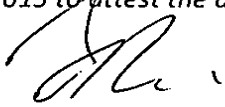
Signature: 

Name(s): TALOFA POULI _____

Authority: STRATA MANAGER _____

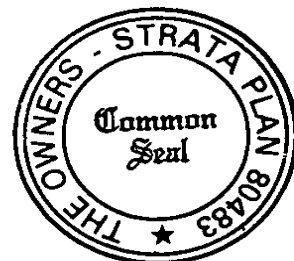

SCHEDULE

LOT	EXCLUSIVE USE AREA
1	EU1
2	EU2
3	EU3
4	EU4
5	EU5

This is page ___ of a total of 25 and is the annexure to the Consolidation/Change of By-Laws form by The Owners – Strata Plan No. 80483

THE SEAL of THE OWNERS – STRATA PLAN NO. 80483 was affixed on the 8th day of January 2018 in the presence of the following person(s) authorised by Section 273 of the Strata Schemes Management Act 2015 to attest the affixing of the seal.

Signature: _____

Name(s): TALOFA POULI _____

Authority: STRATA MANAGER _____



Req:25/0125 /Doc:DL AK24213 /Rev:25-Sep-2008 /Cte:100.0% /Prt:21-Dec-2010 12:21 /Pgs:11/16 /Seq:1 of 5
 Ref:10/0120 /Rev:R

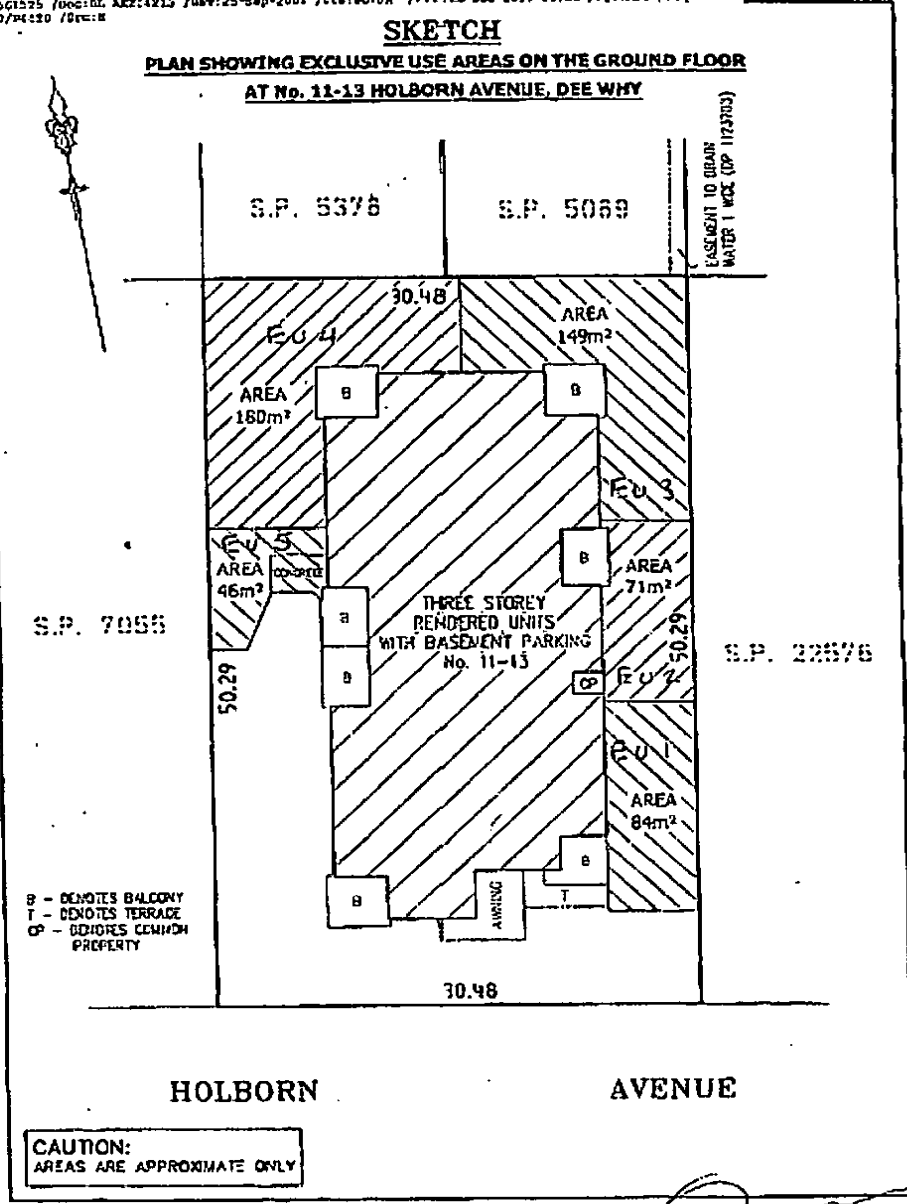

This is page ___ of a total of 25 and is the annexure to the Consolidation/Change of By-Laws form by The Owners – Strata Plan No. 80483

THE SEAL of THE OWNERS – STRATA PLAN NO. 80483 was affixed on the 8th day of January 2018 in the presence of the following person(s) authorised by Section 273 of the Strata Schemes Management Act 2015 to attest the affixing of the seal.

Signature: _____
 Name(s): TALOFA POULI _____
 Authority: STRATA MANAGER _____

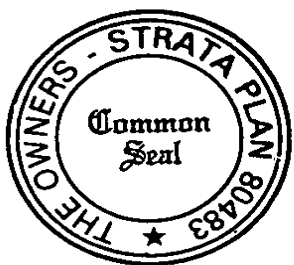

10123

Special By-Law 2: Awning Lot 16

On the conditions set out below in this by-law, the Owner for the time being of Lot 16 ("the Owner") shall have a special privilege to install, and thereafter to maintain for their exclusive enjoyment, a retractable awning to the common property balcony of Lot 16 ("the works"), together with a special privilege to remove such retractable awning and to reinstate such part of the common property, at any time.

CONDITIONS

- 1) Before commencing the Works, the Owner must furnish the Owners Corporation with the following, if applicable:
 - a) A copy of the contract between the Owner and each contractor engaged or to be engaged in relation to the Works;
 - b) A copy of the Contractors All Risk insurance policy which includes public liability cover of not less than \$10,000,000 in respect of any single claim, and evidence that it is current.
- 2) In exercising the special privilege conferred by the by-law the Owner or any authorised occupier of the Lot must:
 - a) Undertake the works in a proper and skilful manner, using proper and appropriate materials and in accordance with any details or requirements of the certifying engineer or qualified tradesman; and
 - b) Undertake the Works in accordance with the Building Code of Australia and all applicable Australian Standards.
- 3) The Owner may not vary the Works except in accordance with the written approval of the Owners Corporation.
- 4) Subject to any amendment of the by-laws from time to time and to any resolution of the Owners Corporation under section 62(3) of the Strata Schemes Management Act 1996 or any replacement legislation, the Owners Corporation will continue to be responsible for the proper maintenance and keeping in a state of good and serviceable repair of the common property.

This is page __ of a total of 25 and is the annexure to the Consolidation/Change of By-Laws form by The Owners – Strata Plan No. 80483

THE SEAL of THE OWNERS – STRATA PLAN NO. 80483 was affixed on the 8th day of January 2018 in the presence of the following person(s) authorised by Section 273 of the Strata Schemes Management Act 2015 to attest the affixing of the seal.

Signature: _____

Name(s): TALOFA POULI _____

Authority: STRATA MANAGER _____

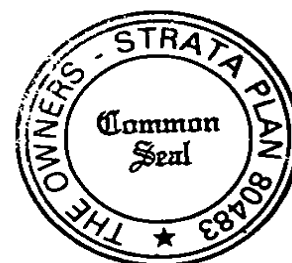

- 5) The Owner must maintain the alteration and addition installed pursuant to this by-law in a state of good and serviceable repair, and must renew or replace the awning wherever necessary.
- 6) The Owner must repair promptly and damage caused or contributed by the Works, including damage to the property of the Owners corporation and the property of the Owner or occupier of another lot in the strata scheme.
- 7) The owner must ensure that the Works and undertaken in a way which minimises the disturbance of the other Owner or occupiers by vibration, noise, dust and dirt.
- 8) The owner must indemnify the Owners Corporation against any liability for damage to property or injury or death of person caused by or arising out of the Works.
- 9) The Owner must meet all reasonable expenses, including legal costs, of the Owners Corporation incurred in the making and registration of this by-law.

Special By law 3: Window Safety Devices

1. For the purposes of this by-law:

- 1.1. "Act" means the *Strata Schemes Management Act 2015* (NSW) as amended from time to time;
- 1.2. "Building" means the building and improvements on the land located at 11-13 Holborn Avenue, Dee Why, NSW, 2099.
- 1.3. "Common Property" means the common property in the Strata Plan;
- 1.4. "Costs" means all professional and trade costs/fees/disbursements;
- 1.5. "Direction" means a written direction from the Owners Corporation to the Owner relating to Remedial Works;

This is page __ of a total of 25 and is the annexure to the Consolidation/Change of By-Laws form by The Owners – Strata Plan No. 80483

THE SEAL of THE OWNERS – STRATA PLAN NO. 80483 was affixed on the 8th day of January 2018 in the presence of the following person(s) authorised by Section 273 of the Strata Schemes Management Act 2015 to attest the affixing of the seal.

Signature: _____

Name(s): TALOFA POULI _____

Authority: STRATA MANAGER _____

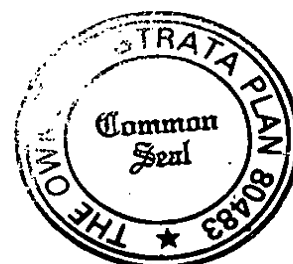

- 1.6. "Indemnify" means the Owner indemnifying the Owners Corporation in respect of the Remedial Works or anything arising from the Remedial Works, including, but not limited to the following:
- 1.6.1. all actions, proceedings, claims, demands, costs, damages and expenses which may be incurred by, brought or made against the Owners Corporation;
 - 1.6.2. any sum payable by way of increased premiums; and
 - 1.6.3. any costs or damages for which the Owners Corporation is or becomes liable;
- 1.7. "Lot" means a lot in the Strata Plan used for residential purposes;
- 1.8. "Occupier" means the legal occupier(s) of a Lot;
- 1.9. "Owner" means the owner(s) of the Lot from time to time;
- 1.10. "Owners Corporation" means the owners corporation known as The Owners - Strata Plan No. 80483, and where the context permits, includes its agents, contractors or employees;
- 1.11. "Penalty" means the penalty or fine under section 118(1) of the Act;
- 1.12. "Remedial Works" means repair, maintenance, removal or replacement of the Window Safety Device and any other items installed as part of the Works, and/or Common Property affected by the Works;
- 1.13. "Residential Tenancy Agreement" means an agreement under which an Owner or Occupier leases, sublets or licenses a Lot on a commercial basis for a period of greater than 3 consecutive months;
- 1.14. "Strata Plan" means registered strata plan number SP 80483;
- 1.15. "Window" means the following:
- 1.15.1. a Common Property window in a Lot that can be opened; and
 - 1.15.2. the lowest level of the window opening is less than 1.7m above the surface of any internal floor of the Lot; and

This is page __ of a total of 25 and is the annexure to the Consolidation/Change of By-Laws form by The Owners – Strata Plan No. 80483

THE SEAL of THE OWNERS – STRATA PLAN NO. 80483 was affixed on the 8th day of January 2018 in the presence of the following person(s) authorised by Section 273 of the Strata Schemes Management Act 2015 to attest the affixing of the seal.

Signature: _____

Name(s): TALOFA POULI _____

Authority: STRATA MANAGER _____

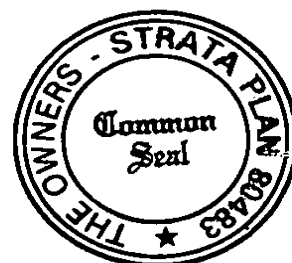

1.15.3. that internal floor is 2m or more above the external surface of the ground below the window.

[An illustration of this definition is attached to this by-law and marked with the letter 'A']

1.16. "Window Safety Device" means a device meeting the following description that is capable of resisting an outward horizontal action of 250 newtons (or 25.5 kilogram-force):

1.16.1. a child safety device that limits the maximum Window opening to 12.5cm or bars or grills that have gaps no bigger than 12.5cm; and

1.16.2. the device is robust and childproof; and

1.16.3. excludes ordinary flyscreens.

1.17. "Works" means the installation or affixing of a Window Safety Device on a Window in accordance with the Office of Fair Trading Window Safety Device Requirements Fact Sheet attached to this by-law and marked with the letter 'B'.

2. Where any terms in this by-law are not defined, they will have the same meaning those words are attributed under the Act.
3. If this by-law empowers the Owners Corporation to take action, it may or may not take such action in its reasonable discretion.

Works

4. The Owners Corporation is responsible for carrying out the Works at a Lot and will pay the Costs of carrying out the Works.
5. An Owner and/or Occupier of a Lot must grant the Owners Corporation access to the Lot for the purpose of carrying out the Works, or determining if the Works are required to be carried out at a Lot.
6. In the event the Owner or Occupier has agreed with the Owners Corporation on a day and time for access, and the Owners Corporation cannot gain access to the Lot on that agreed day and time due to any action or inaction of the Owner or Occupier, the relevant Owner or Occupier is responsible for any Costs incurred by the Owners Corporation for re-arranging the access.

This is page __ of a total of 25 and is the annexure to the Consolidation/Change of By-Laws form by The Owners – Strata Plan No. 80483

THE SEAL of THE OWNERS – STRATA PLAN NO. 80483 was affixed on the 8th day of January 2018 in the presence of the following person(s) authorised by Section 273 of the Strata Schemes Management Act 2015 to attest the affixing of the seal.

Signature: _____

Name(s): TALOFA POULI _____

Authority: STRATA MANAGER _____

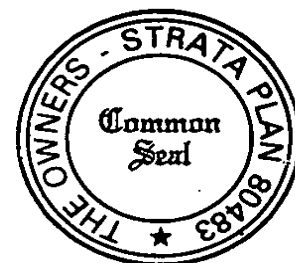

7. Upon completion of the Works at a Lot, the Owner or Occupier of that Lot must sign a written acknowledgement form provided by the Owners Corporation for the purpose of confirming that Works have been carried out at the Lot.
8. Prior to providing the written acknowledgement form as referred to in clause 7 above, the Owners Corporation may request an Occupier to provide a copy of their Residential Tenancy Agreement and proof of identity, such as a driver's licence or passport, as evidence that they are the tenant(s) identified in the Residential Tenancy Agreement.

Remedial Works

9. The Owner is responsible for and must carry out Remedial Works when and where necessary, including by Direction.
10. The Remedial Works must be carried out and completed:
 - 10.1. in a proper workmanlike manner and by licensed and/or accredited contractors;
 - 10.2. with due skill and care using proper materials;
 - 10.3. in compliance with the Building Code of Australia, any other Australian Standards, as applicable;
 - 10.4. in keeping with the appearance of the Building in its style, colour, materials and overall design;
 - 10.5. in a way so as to not unreasonably interfere with the enjoyment of other Common Property areas or access to lots in the strata scheme by other persons by building materials, tools, machines, debris or motor vehicles;
 - 10.6. in a way which minimises the disturbance to other Owners including but not limited to vibration, noise, dust and dirt;
 - 10.7. in compliance with all local council consents and requirements (if any);
 - 10.8. ensuring that the security of the Building is maintained throughout the performance of the Remedial Works;
 - 10.9. promptly and completely removing all rubbish from the Building resulting from the Remedial Works;
 - 10.10. keeping all areas of the Building as clean and tidy as possible;

This is page __ of a total of 25 and is the annexure to the Consolidation/Change of By-Laws form by The Owners – Strata Plan No. 80483

THE SEAL of THE OWNERS – STRATA PLAN NO. 80483 was affixed on the 8th day of January 2018 in the presence of the following person(s) authorised by Section 273 of the Strata Schemes Management Act 2015 to attest the affixing of the seal.

Signature: _____

Name(s): TALOFA POULI _____

Authority: STRATA MANAGER _____

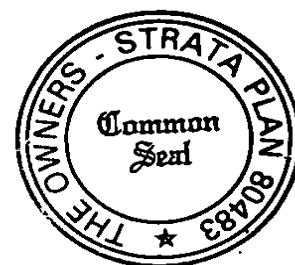

18. In the event the Owner responsible for the Penalty does not reimburse the Penalty and Costs to the Owners Corporation within 28 days of receiving written notice of the charges from the Owners Corporation, the Owners Corporation may charge the amount to the Owner's lot account, as if it were a contribution under Act, with all associated rights of recovery under the Act.

General obligations

19. Owners and Occupiers will sign all documents and do all things necessary to facilitate the matters the subject of this by-law.

20. Owners and Occupiers will not claim upon the Owners Corporation's insurance in respect of anything arising out of the Remedial Works.

21. The Owner will indemnify and will keep indemnified the Owners Corporation.

This is page __ of a total of 25 and is the annexure to the Consolidation/Change of By-Laws form by The Owners – Strata Plan No. 80483

THE SEAL of THE OWNERS – STRATA PLAN NO. 80483 was affixed on the 8th day of January 2018 in the presence of the following person(s) authorised by Section 273 of the Strata Schemes Management Act 2015 to attest the affixing of the seal.

Signature: _____

Name(s): TALOFA POULI _____

Authority: STRATA MANAGER _____

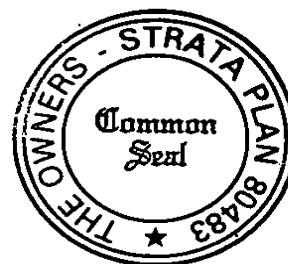

ANNEXURE 'A'

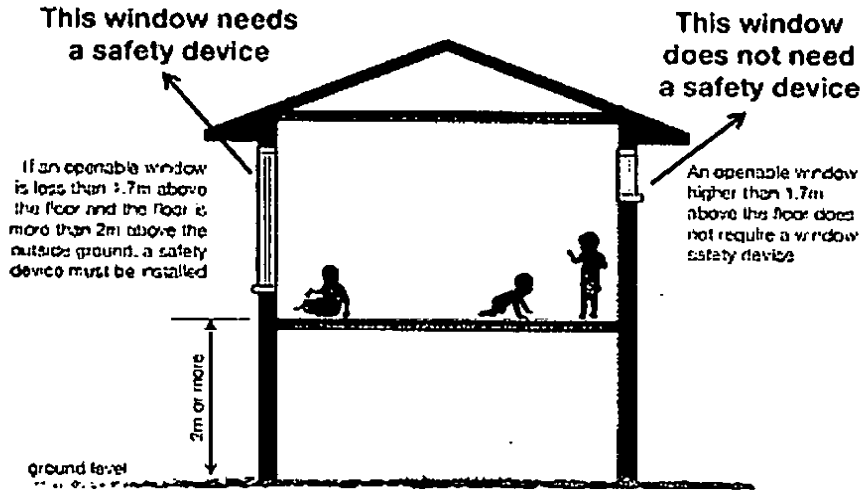

This is page ___ of a total of 25 and is the annexure to the Consolidation/Change of By-Laws form by The Owners – Strata Plan No. 80483

THE SEAL of THE OWNERS – STRATA PLAN NO. 80483 was affixed on the 8th day of January 2018 in the presence of the following person(s) authorised by Section 273 of the Strata Schemes Management Act 2015 to attest the affixing of the seal.

Signature: _____

Name(s): TALOFA POULI _____

Authority: STRATA MANAGER _____

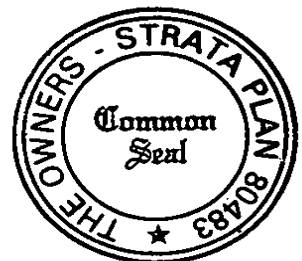

“B”

FACT SHEET

September 2015

Window safety device requirements

In strata schemes

To prevent children falling from windows, all strata buildings in NSW must be fitted with devices that enable their windows to be locked at 12.5cm when the devices are engaged. Owners corporations must have devices installed on all common property windows above the ground floor by 13 March 2018. The safety devices must be robust and childproof.

Residents will still be able to open their windows. However, they will have the security of knowing that when the locks are engaged, children will be protected.

Did you know? Similar laws in New York resulted in a 95 per cent decrease in hospitalisations due to falls from windows.

Are there any alternatives to locks?

The alternative is security screens, such as bars or grills on the windows so long as they have gaps no bigger than 12.5cm. Fyscreens do not comply unless they are the reinforced security type and capable of resisting the very strong outward pressure which would prevent a child falling through.

For a handy window safety product guide, visit the Kids Don't Fly page on the Kids Health website at www.kidshhealth.nsw.health.nsw.gov.au. Information is provided in 11 languages.

Which windows does this apply to?

The laws apply to openable windows more than 2m above the ground floor outside and within a child's reach (less than 1.7m above the inside floor) – see the diagram below.

The details are explained in the Strata Schemes Management Regulation 2010.

When do the locks need to be installed?

If the window safety requirements are not met by 13 March 2018, owners corporations face fines. Leaving it to the last minute places your scheme at risk of not complying by the due date and leaves young children vulnerable to falls from windows in your scheme.

Lot owners may install a window safety device in their property at any time, letting the owners corporation know. Tenants must get written permission from their landlord before installing locks that require drilling. Landlords cannot refuse a tenant's request unless they have a very good reason.

Watch our "Window locks and your rights" video for details on your rights and obligations as a tenant, landlord or strata owner when it comes to installing locks, available from our website and YouTube channel.

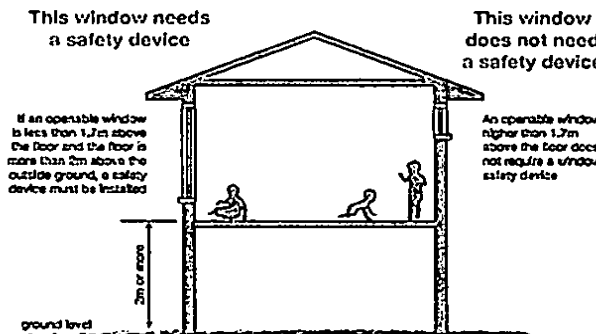

www.fairtrading.nsw.gov.au



This is page ___ of a total of 25 and is the annexure to the Consolidation/Change of By-Laws form by The Owners – Strata Plan No. 80483

THE SEAL of THE OWNERS – STRATA PLAN NO. 80483 was affixed on the 8th day of January 2018 in the presence of the following person(s) authorised by Section 273 of the Strata Schemes Management Act 2015 to attest the affixing of the seal.

Signature:

Name(s): TALOFA POULI

Authority: STRATA MANAGER

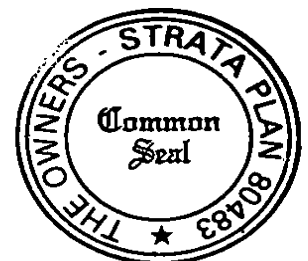

19125

FACT SHEET

September 2015

Will this mean the windows will never be able to open?

No. A window lock that allows the window to be fully opened, fully closed and also locked at 12.5cm complies with the legislation. When children are in the apartment, or on all common access areas such as stair landings, it makes sense to engage the locks at 12.5cm or less at all times to prevent falls.

How can we arrange for locks in our scheme that won't cost a fortune?

Window safety devices can be easy and cheap to install. It is not necessary to hire a consultant to do an initial assessment. Owners corporations may simply get quotes from a range of appropriately qualified tradespeople and then choose the best one. Refer to our short 'Window locks save lives' video series including a step-by-step DIY video 'How to install window locks', available from our website and YouTube channel.

If the windows have grills over them, do they still need locks?

If the grills or bars over the windows are no more than 12.5cm apart in width then they may comply with the regulation. The law requires the window safety devices to be robust and childproof. Remember, ordinary flyscreens do not comply as they are not strong enough to stop a child falling through a window and can provide a false sense of security.

Will the safety devices be included in the Tenancy Condition Report?

Landlords and tenants entering into a new tenancy agreement must use an up-to-date Residential Tenancy Condition Report which lists window safety devices. You can download the new condition report from the Forms page.

Where can I get more information?

If you are a tenant, go to the Asking to make an alteration page for information about making minor changes to your home including installing window locks.

If you are a landlord, go to the Alteration requests from your tenant page for more information.

If you own a strata unit, more information about your rights and responsibilities is available from the Repairs and maintenance in a strata scheme page.

If you need more details about the laws, please refer to the *Strata Schemes Management Act 1996* No 138 or call us on 13 32 20.

www.fairtrading.nsw.gov.au
Fair Trading enquiries 13 32 20
TTY 1300 723 404
Language assistance 13 34 50

This fact sheet must not be relied on as legal advice. For more information about this topic, refer to the appropriate legislation.

© State of New South Wales through NSW Fair Trading.
You may freely copy, distribute, display or download this information with some important restrictions. See NSW Fair Trading's copyright policy at www.fairtrading.nsw.gov.au or email publications@fairtrading.nsw.gov.au

www.fairtrading.nsw.gov.au



This is page ___ of a total of 25 and is the annexure to the Consolidation/Change of By-Laws form by The Owners – Strata Plan No. 80483

THE SEAL of THE OWNERS – STRATA PLAN NO. 80483 was affixed on the 8th day of January 2018 in the presence of the following person(s) authorised by Section 273 of the Strata Schemes Management Act 2015 to attest the affixing of the seal.

Signature: _____

Name(s): TALOFA POULI _____

Authority: STRATA MANAGER _____

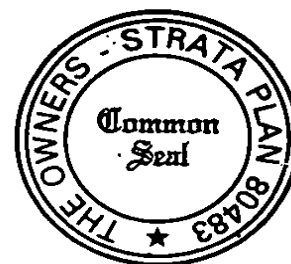

20125 .

Special By-law No. 4 Minor Renovations

Rights

1. On the conditions set out in this by-law and with the prior written approval of the strata committee each Owner has the authority to carry out Minor Renovations to the common property in connection with the Owner's lot and, once installed, to maintain the approved Minor Renovations.
2. The owners corporation delegates its power to approve Minor Renovations to the strata committee.
3. The strata committee, when considering an Owner's proposal to conduct Minor Renovations may impose conditions on any approval and must not unreasonably withhold their approval.

Definitions

4. In this by-law, the following terms are defined to mean:
 - a. "Act" means the *Strata Schemes Management Act 2015* (NSW);
 - b. "Building" means the building located at 11-13 Holborn Avenue, Dee Why, NSW, 2099;
 - c. "Minor Renovations" includes work for the purposes of the following:
 - i. renovating a kitchen,
 - ii. changing recessed light fittings,
 - iii. installing or replacing wood or other hard floors,
 - iv. installing or replacing wiring or cabling or power or access points,
 - v. work involving reconfiguring walls,
 - vi. removing carpet or other soft floor coverings to expose underlying wooden or other hard floors,

This is page ___ of a total of 25 and is the annexure to the Consolidation/Change of By-Laws form by The Owners – Strata Plan No. 80483

THE SEAL of THE OWNERS – STRATA PLAN NO. 80483 was affixed on the 8th day of January 2018 in the presence of the following person(s) authorised by Section 273 of the Strata Schemes Management Act 2015 to attest the affixing of the seal.

Signature: _____

Name(s): TALOFA POULI _____

Authority: STRATA MANAGER _____

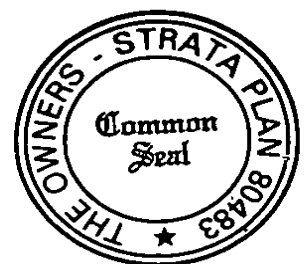

21 / 25

- vii. installing a rainwater tank,
- viii. installing a clothesline,
- ix. installing a reverse cycle split system air conditioner,
- x. installing double or triple glazed windows,
- xi. installing a heat pump,
- xii. installing ceiling insulation.

but does not include works set out in section 110(7) of the Act such as work involving structural changes, waterproofing, changes to the external appearance of a lot or requiring consent or other approval under any other statute, regulation or the like.:

- d. "Owner" means an owner of a lot from time to time in the strata scheme;
5. Where any terms used in this by-law are defined in the Act, they will have the same meaning as those words are attributed under the Act.
6. Words importing:
- a. the singular include the plural and vice versa; and
 - b. a gender includes any gender.
7. A reference to a statute, regulation, proclamation, ordinance or by-law includes all statutes, regulations, proclamations, ordinances or by-laws varying, consolidating or replacing them, and a reference to a statute includes all regulations, proclamations, ordinances and by-laws issued under that statute.

Prior to Conducting the Minor Renovations

8. An Owner must make an application to the owners corporation for its approval to conduct the Minor Renovations by giving written notice of their proposed works to the owners corporation with the notice to include:

This is page __ of a total of 25 and is the annexure to the Consolidation/Change of By-Laws form by The Owners – Strata Plan No. 80483

THE SEAL of THE OWNERS – STRATA PLAN NO. 80483 was affixed on the 8th day of January 2018 in the presence of the following person(s) authorised by Section 273 of the Strata Schemes Management Act 2015 to attest the affixing of the seal.

Signature: _____

Name(s): TALOFA POULI _____

Authority: STRATA MANAGER _____

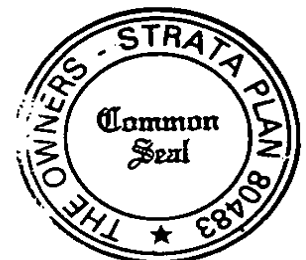

22125

- a. details of the work, including copies of any plans,
 - b. the expected duration and times of the works,
 - c. details of the persons carrying out the work including that person's qualifications to carry out the work, and
 - d. arrangements to manage any resulting rubbish or debris.
9. Prior to conducting the Minor Renovations, the Owner and/or the tradesperson appointed by the Owner to carry out the Works must effect, and provide the owners corporation with certificates of, the following insurances:
- a. contractor's all risk insurance (where applicable);
 - b. workers compensation insurance (where applicable);
 - c. home owners warranty Insurance (where applicable); and
 - d. public liability insurance in the amount of \$10,000,000 including for and in respect of equipment located and/or utilised on common property in execution of the Minor Renovations.

Performance of the Works

10. In carrying out or maintaining the Minor Renovations the Owner must:
- a. ensure that the works are completed in a competent and proper manner and in accordance with the Building Code of Australia and relevant Australian Standards;
 - b. transport each item including but not limited to construction materials, equipment and debris in the manner reasonably directed by the owners corporation;
 - c. protect all areas of the Building both internal and external to the lot in a manner reasonably acceptable to the owners corporation;
 - d. keep all areas of the common property outside the lot clean and tidy;
 - e. only perform Minor Renovations at times approved by the owners corporation;

This is page __ of a total of 25 and is the annexure to the Consolidation/Change of By-Laws form by The Owners – Strata Plan No. 80483

THE SEAL of THE OWNERS – STRATA PLAN NO. 80483 was affixed on the 8th day of January 2018 in the presence of the following person(s) authorised by Section 273 of the Strata Schemes Management Act 2015 to attest the affixing of the seal.

Signature: _____

Name(s): TALOFA POULI _____

Authority: STRATA MANAGER _____

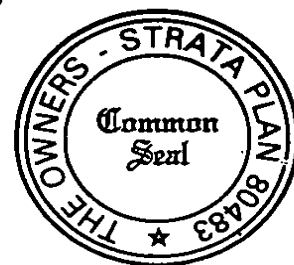

- f. not create noise which causes discomfort, disturbance, obstruction or interference with the activities of any other occupier of the Building;
- g. immediately remove all debris or waste resulting from the Minor Renovations from the Building and the common property;
- h. not vary or replace the Minor Renovations, as agreed to by the strata committee, without the prior written approval of the strata committee; and
- i. ensure that the Minor Renovations do not interfere with or damage the common property, or any lot or property of any other lot owner or occupier (other than as approved in by the strata committee) and if this happens the Owner must rectify that interference or damage within a reasonable period of time.

Maintenance of the Minor Renovations

- 11. The Owner must properly maintain and keep the Minor Renovations and the common property to which they are attached in a state of good and serviceable repair.

Liability and Indemnity

- 12. The Owner is liable for any damage caused to any part of the common property, and any lot (including their lot), or other property arising from the Minor Renovations and will make good that damage immediately after it has occurred.
- 13. The Owner indemnifies the owners corporation against any legal liability, loss, damage, claim or proceedings that relates to the installation, performance, maintenance, replacement or removal of the Minor Renovations on or from the common property including but not limited to any liability under section 122(6) of the Act in respect of any property of the Owner.

Owner's Fixtures

- 14. The Minor Renovations shall remain the Owner's fixture.

Cost and Risk of the Works

- 15. The Minor Renovations (including their replacement or removal) are undertaken at the cost and risk of the Owner.

This is page ___ of a total of 25 and is the annexure to the Consolidation/Change of By-Laws form by The Owners – Strata Plan No. 80483

THE SEAL of THE OWNERS – STRATA PLAN NO. 80483 was affixed on the 8th day of January 2018 in the presence of the following person(s) authorised by Section 273 of the Strata Schemes Management Act 2015 to attest the affixing of the seal.

Signature: _____

Name(s): TALOFA POULI _____

Authority: STRATA MANAGER _____



Right to Remedy Upon Default

16. If an Owner fails to comply with any obligation under this by-law, then the owners corporation may:
- a. carry out all work necessary to perform that obligation;
 - b. in accordance with the provisions of the Act enter upon any part of the parcel to carry out that work;
 - c. recover the costs of carrying out that work from the Owner.
17. The costs referred to in paragraph 16(c) of this by-law may include any costs incurred by the owners corporation in carrying out any building repair work, security call-out charges, after hours building management or agency fees, administrative and legal costs to issue correspondence or any notices pursuant to this by-law and any other reasonable cost expended by the owners corporation in rectifying any damage occasioned to the common property by the respective Owner or in enforcing the terms of this by-law against the Owner of the lot.
18. If the costs referred to in paragraph 16(c) of this by-law are not paid at the end of one month after becoming due and payable they shall bear, until paid, simple interest at an annual rate of 10% and the owners corporation may recover as a debt any costs payable by the Owner pursuant to this by-law, not paid at the end of one month after they become due and payable, together with any interest payable and the expenses of the Owners Corporation incurred in recovering those amounts.

This is page ___ of a total of 25 and is the annexure to the Consolidation/Change of By-Laws form by The Owners – Strata Plan No. 80483

THE SEAL of THE OWNERS – STRATA PLAN NO. 80483 was affixed on the 8th day of January 2018 in the presence of the following person(s) authorised by Section 273 of the Strata Schemes Management Act 2015 to attest the affixing of the seal.

Signature: _____

Name(s): TALOFA POULI _____

Authority: STRATA MANAGER _____



FILM WITH
AN95862

Approved Form 10

Certificate re Initial Period

The owners corporation certifies that in respect of the strata scheme:

*that the initial period has expired.

~~*the original proprietor owns all of the lots in the strata scheme and any purchaser under an exchanged contract for the purchase of a lot in the scheme has consented to any plan or dealing being lodged with this certificate.~~

The seal of The Owners - Strata Plan No 80483 was affixed on ^ 8/1/2018 in the presence of the following person(s) authorised by section 273 *Strata Schemes Management Act 2015* to attest the affixing of the seal.

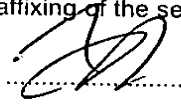
Signature:  Name: TALOFA POU1 Authority: STRATA MANAGER

Signature: Name: Authority:

^ Insert appropriate date
* Strike through if inapplicable.



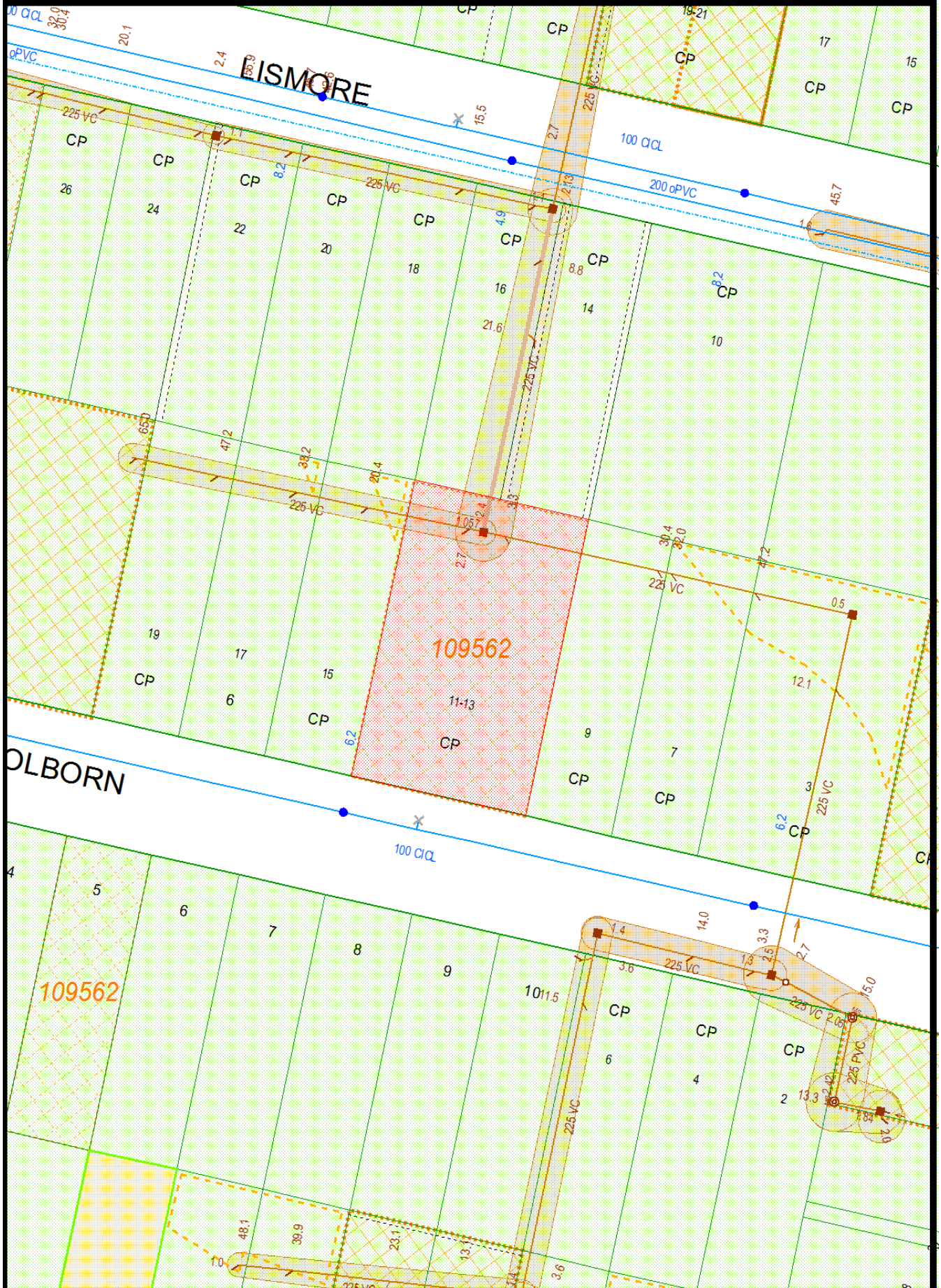

NOTE This diagram only indicates availability of a sewer and any sewerage service shown as existing in Sydney Water's records. The existence and position of Sydney Water's sewers, stormwater channels, pipes, mains and structures should be ascertained by inspection of maps available at any of Sydney Water's Customer Centres. Position of structures, boundaries, sewers and sewerage services shown hereon are approximately only.

SYDNEY WATER SEWERAGE SERVICE DIAGRAM

MUNICIPALITY OF WARRINGAH

SUBURB OF Dee Why

SSD 7015703

INDICATES - DRAINAGE FITTINGS		SYMBOLS AND ABBREVIATIONS				INDICATES - PLUMBING ON MORE THAN ONE LEVEL	
■	Manhole	⊠ P	P. Trap	CO	Clean out	Bid	Bidet
□ Chr	Chamber	■ R	Reflux Valve	O V	Vent Pipe	S	Shower
● LH	Lamphole	◊	Cleaning Eye	T	Tube	DW	Dishwasher
⊗	Boundary Trap	● Vert	Vertical Pipe	K	Kitchen Sink	F	Floor Waste
⊕	Inspection Shaft	IP	Induct Pipe	W	Water Closet	M	Washing Machine
■ Pit	Pit	MF	Mica Flap	B	Bath Waste	BS	Bar Sink
EG	Grease Interceptor	● RP	Rodding Point	H	Handbasin	LS	Lab Sink
⊠	Gully	↘	Sloped Junction	INDICATES - PLUMBING ON MORE THAN ONE LEVEL			
⊙ TMS	Terminal Maint. Shaft	⊖	Vertical Junction	○ SVP	Soil Vent Pipe	○ WS	Waste Stack
⊙ MS	Maintenance Shaft	↖	On back Junction				
						---	ELEC.
						⊖	Pump Unit
						⊠	Boundary Valve
						⊠ PRV	Boundary Valve with PRV
						⊠	Alarm Control Panel
						⊠	LP Stop Valve
						▷	LP Air Valve
						+	LP Reducer
						⊕	HSV Flow Monitor
						⊕	Vacuum Chamber
						⊕	Flushing Point

Scale: Approx 1:500 Distances/depths in metres Pipe diameters in millimetres Boundary Trap not required

SEWER AVAILABLE

Where the sewer is not available and a special inspection is involved the Board accepts no responsibility for the suitability of the drainage in relation to the eventual position of the Board's sewer. The existence and position of the Board's sewers, stormwater channels, pipes, mains and structures should be ascertained by inspection of records available at Board's Business Offices. (Section 33 of Board's Act). Position of structures, boundaries, sewers and sewerage service shown hereon are approximate only and in general the outlines of building may have been drawn from initial building plans submitted to the Board. Discrepancies in outline can occur from amendment to these plans. Discrepancies in position and type of drainage lines and fittings can be due to unnotified work. Before building work is commenced location of drainage lines is recommended. Licensee is required to submit to the Board a Certificate Of Compliance as not all work may have been supervised.

NOTE: This diagram only indicates availability of a sewer and any sewerage service as existing in the Board's records (By-Law 8, Clause 3).

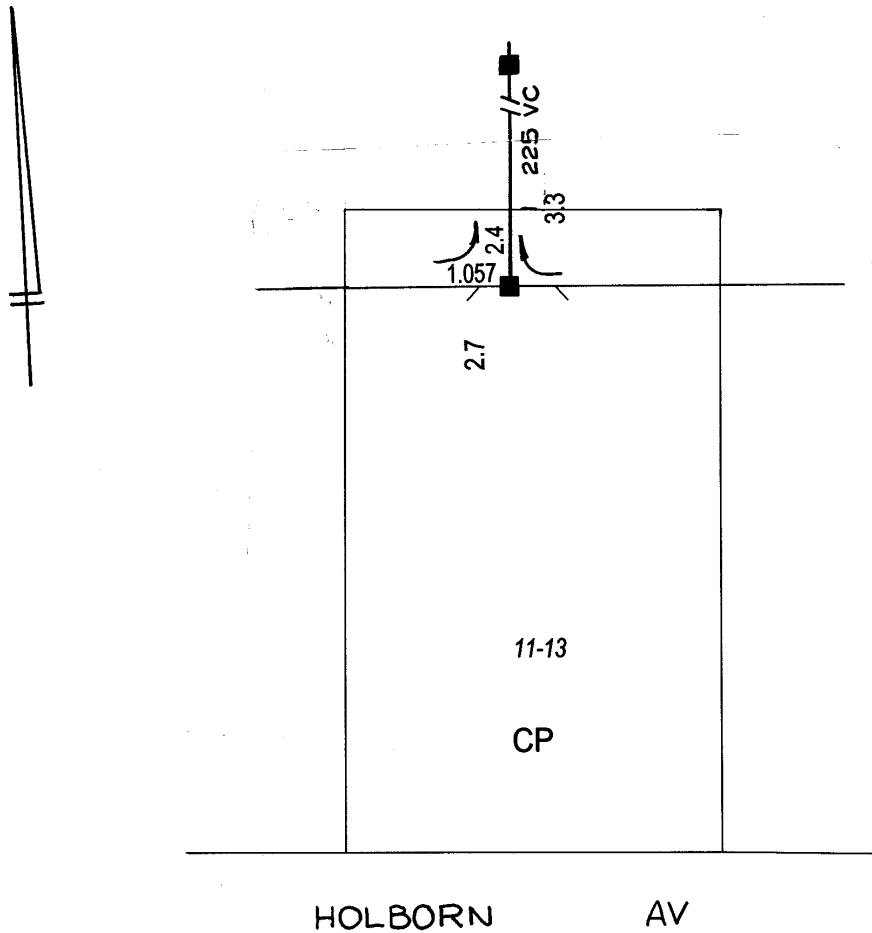

NOTE This diagram only indicates availability of a sewer and any sewerage service shown as existing in Sydney Water's records. The existence and position of Sydney Water's sewers, stormwater channels, pipes, mains and structures should be ascertained by inspection of maps available at any of Sydney Water's Customer Centres. Position of structures, boundaries, sewers and sewerage services shown hereon are approximately only.

Northern Beaches Council Planning Certificate – Part 2

Applicant: InfoTrack
GPO Box 4029
Sydney NSW 2001

Reference: Yoshi
Date: 01/06/2020
Certificate No. ePLC2020/3224

Address of Property: 17/11-13 Holborn Avenue DEE WHY NSW 2099
Description of Property: Lot 17 SP 80483

Planning Certificate – Part 2

The following certificate is issued under the provisions of Section 10.7(2) of the *Environmental Planning and Assessment Act 1979* (as amended – formerly Section 149). The information applicable to the land is accurate as at the above date.

1. Relevant planning instruments and Development Control Plans

1.1 The name of each environmental planning instrument that applies to the carrying out of development on the land:

1.1a) Local Environmental Plan

Warringah Local Environmental Plan 2011

1.1b) State Environmental Planning Policies and Regional Environmental Plans

State Environmental Planning Policy 19 – Bushland in Urban Areas
State Environmental Planning Policy 21 – Caravan Parks
State Environmental Planning Policy 33 – Hazardous and Offensive Development
State Environmental Planning Policy 50 – Canal Estate Development
State Environmental Planning Policy 55 – Remediation of Land
State Environmental Planning Policy 64 – Advertising and Signage
State Environmental Planning Policy 65 – Design Quality of Residential Apartment Development
State Environmental Planning Policy No 70—Affordable Housing (Revised Schemes)
State Environmental Planning Policy (Affordable Rental Housing) 2009
State Environmental Planning Policy (Building Sustainability Index: BASIX) 2004
State Environmental Planning Policy (Educational Establishments and Child Care Facilities) 2017
State Environmental Planning Policy (Exempt and Complying Development Codes) 2008
State Environmental Planning Policy (Housing for Seniors or People with a Disability) 2004
State Environmental Planning Policy (Infrastructure) 2007

State Environmental Planning Policy (Mining, Petroleum Production and Extractive Industries) 2007

State Environmental Planning Policy (State and Regional Development) 2011

State Environmental Planning Policy (State Significant Precincts) 2005

State Environmental Planning Policy (Vegetation in Non-Rural Areas) 2017

State Environmental Planning Policy (Primary Production and Rural Development) 2019

State Environmental Planning Policy (Koala Habitat Protection) 2019

Wholly Affected - State Environmental Planning Policy (Coastal Management) 2018

Sydney Regional Environmental Plan No 20-Hawkesbury-Nepean River (No 2-1997)

Sydney Regional Environmental Plan (Sydney Harbour Catchment) 2005

Sydney Regional Environmental Plan No 9-Extractive Industry (No 2-1995)

1.2 Draft Environmental Planning Instruments

The name of each proposed environmental planning instrument that will apply to the carrying out of development on the land and that is or has been subject of community consultation or on public exhibition under the Act (unless the Secretary has notified the Council that the making of the proposed instrument has been deferred indefinitely or has not been approved):

1.2 a) Draft State Environmental Planning Policies

Draft State Environmental Planning Policy (Environment)

Draft State Environmental Planning Policy (Short-term Rental Accommodation) 2019

Amendment to State Environmental Planning Policy (Exempt and Complying Development Codes) 2008

Draft Remediation of Land State Environmental Planning Policy (intended to replace State Environmental Planning Policy 55)

1.2 b) Draft Local Environmental Plans

Planning Proposal - Manly Creek Riparian Lands, Manly Vale (in the vicinity of “Mermaid Pool”)

Applies to: Crown Land:

- Part Lot 7370 DP1165551 being land adjoining 102 King Street, Manly Vale
- Part Lot 7369 DP1165551 Wandella Road, Allambie Heights, south of Jenna Close, Allambie heights
- Lot 7371 DP1165577
- Part unmade road at the southern end of Wandella Road, King Street, Manly Vale

Outline: Proposed amendment to WLEP 2011 to:

- Amend Land Zoning Map to change the zoning from R2 (Low Density Residential) to RE1 (Public Recreation).
- Amend Height of Building Map and Minimum Lot Size Map to remove the residential development standards for height and minimum lot size from all of the subject lots.

Council resolution: 27 November 2018

Gateway Determination: 9 August 2019

Planning Proposal - Freshwater Village Carpark Reclassification

Applies to land: Oliver Street carpark and Lawrence Street carpark, Freshwater

Outline: Amends WLEP 2011 to:

- Amend Schedule 4 Part 1 to include reference to the land
- Amend LZN_010 map to change the zoning from RE1 - Public Recreation to SP2 - Infrastructure
- Amend HOB_010 map to implement a maximum height of building of 3 metres.

Council resolution: 27 November 2018

Gateway determination: 23 September 2019

1.3 Development Control Plans

The name of each development control plan that applies to the carrying out of development on the land:

Warringah Development Control Plan 2011

2. Zoning and land use under relevant Local Environmental Plans

For each environmental planning instrument or proposed instrument referred to in Clause 1 (other than a SEPP or proposed SEPP) that includes the land in any zone (however described):

2.1 Zoning and land use under relevant Local Environmental Plans

2.1 (a), (b), (c) & (d)

The following information identifies the purposes for which development may be carried out with or without development consent and the purposes for which the carrying out of development is prohibited, for all zones (however described) affecting the land to which the relevant Local Environmental Plan applies.

EXTRACT FROM WARRINGAH LOCAL ENVIRONMENTAL PLAN 2011

Zone R3 Medium Density Residential

1 Objectives of zone

- To provide for the housing needs of the community within a medium density residential environment.
- To provide a variety of housing types within a medium density residential environment.
- To enable other land uses that provide facilities or services to meet the day to day needs of residents.
- To ensure that medium density residential environments are characterised by landscaped settings that are in harmony with the natural environment of Warringah.
- To ensure that medium density residential environments are of a high visual quality in their presentation to public streets and spaces.

2 Permitted without consent

Home-based child care; Home occupations

3 Permitted with consent

Attached dwellings; Bed and breakfast accommodation; Boarding houses; Boat sheds; Building identification signs; Business identification signs; Centre-based child care facilities; Community facilities; Dual occupancies; Dwelling houses; Educational establishments; Emergency services facilities; Environmental protection works; Exhibition homes; Group homes; Home businesses; Multi dwelling housing; Neighbourhood shops; Places of public worship; Recreation areas; Residential flat buildings; Respite day care centres; Roads; Secondary dwellings; Seniors housing; Veterinary hospitals

4 Prohibited

Pond-based aquaculture; Any other development not specified in item 2 or 3

Additional permitted uses

Additional permitted uses, if any, for which development is permissible with development consent pursuant to Clause 2.5 and Schedule 1 of the relevant Local Environmental Plan:

Nil

(e) Minimum land dimensions

The *Warringah Local Environmental Plan 2011* contains no development standard that fixes minimum land dimensions for the erection of a dwelling house on the land.

(f) Critical habitat

The land does not include or comprise critical habitat.

(g) Conservation areas

The land is not in a heritage conservation area.

(h) Item of environmental heritage

The land does not contain an item of environmental heritage.

2.2 Draft Local Environmental Plan - if any

For any proposed changes to zoning and land use, see Part 1.2 b)

Please contact Council's Strategic and Place Planning unit with enquiries on 1300 434 434.

2A. Zoning and land use under State Environmental Planning Policy (Sydney Region Growth Centres) 2006

The *State Environmental Planning Policy (Sydney Region Growth Centres) 2006* does not apply to the land.

3. Complying Development

The extent to which the land is land on which complying development may or may not be carried out under each of the codes for complying development because of the provisions of clauses 1.17A (1) (c) to (e), (2), (3) and (4), 1.18 (1) (c3) and 1.19 of *State Environmental Planning Policy (Exempt and Complying Development Codes) 2008*.

a) Housing Code

Complying Development under the Housing Code may be carried out on all of the land.

b) Rural Housing Code

Complying Development under the Rural Housing Code may be carried out on all of the land.

c) Low Rise Medium Density Code

Complying Development under the Low Rise Medium Density Code may not be carried out on all the land.

Note: Pursuant to clause 3B.63 of the *State Environmental Planning Policy (Exempt and Complying Development Codes) 2008*, all land in Northern Beaches Council is a 'deferred area' meaning that the Low Rise Medium Density Code does not apply until 1 July 2020.

d) Greenfield Housing Code

Complying Development under the Greenfield Housing Code may not be carried out on all of the land.

e) Housing Alterations Code

Complying Development under the Housing Alterations Code may be carried out on all of the land.

f) General Development Code

Complying Development under the General Development Code may be carried out on all of the land.

g) Commercial and Industrial Alterations Code

Complying Development under the Commercial and Industrial Alterations Code may be carried out on all of the land.

h) Commercial and Industrial (New Buildings and Additions) Code

Complying Development under the Commercial and Industrial (New Buildings and Additions) Code may be carried out on all of the land.

i) Container Recycling Facilities Code

Complying Development under the Container Recycling Facilities Code may be carried out on all of the land.

j) Subdivisions Code

Complying Development under the Subdivisions Code may be carried out on all of the land.

k) Demolition Code

Complying Development under the Demolition Code may be carried out on all of the land.

l) Fire Safety Code

Complying Development under the Fire Safety Code may be carried out on all of the land.

m) Inland Code

Complying Development under the Inland Code does not apply to the land.

Note: Pursuant to clause 3D.1 of the *State Environmental Planning Policy (Exempt and Complying Development Codes) 2008*, the Inland Code only applies to 'inland local government areas'. Northern Beaches local government area is not defined as an 'inland local government area' by *State Environmental Planning Policy (Exempt and Complying Development Codes) 2008*.

4, 4A (Repealed)

4B. Annual charges under Local Government Act 1993 for coastal protection services that relate to existing coastal protection works

The owner of the land (or any previous owner) has not consented in writing to the land being subject to annual charges under section 496B of the *Local Government Act 1993* for coastal protection services that relate to existing coastal protection works (within the meaning of section 553B of that Act).

5. Mine Subsidence

The land has not been proclaimed to be a mine Subsidence (Mine Subsidence) district within the meaning of section 15 of the *Mine Subsidence (Mine Subsidence) Compensation Act, 1961*.

6. Road widening and road realignment

- (a) The land is not affected by a road widening or re-alignment proposal under Division 2 of Part 3 of the *Roads Act 1993*.
- (b) The land is not affected by a road widening or re-alignment proposal under an environmental planning instrument.
- (c) The land is not affected by a road widening or re-alignment proposal under a resolution of Council.

7. Council and other public authority policies on hazard risk restriction

- (a) Council has adopted a number of policies with regard to various hazards or risks which may restrict development on this land. The identified hazard or risk and the respective Council policies which affect the property, if any, are listed below (other than flooding – see 7A):

Nil

- (b) The following information applies to any policy as adopted by any other public authority and notified to the Council for the express purpose of its adoption by that authority being referred to in a planning certificate issued by the Council. The identified hazard or risk and the respective Policy which affect the property, if any, are listed below:

Nil

7A. Flood related development control Information

- (1) Development on the land or part of the land for the purposes of dwelling houses, dual occupancies, multi dwelling housing or residential flat buildings (not including development for the purposes of group homes or seniors housing) is not subject to flood related development controls.
- (2) Development on the land or part of the land for any other purpose is not subject to flood related development controls.

8. Land reserved for acquisition

Environmental planning instrument referred to in Clause 1 does not make provision in relation to the acquisition of the land by a public authority, as referred to in section 3.15 of the Act.

9. Contribution plans

The following applies to the land:

Northern Beaches Section 7.12 Contributions Plan 2019

9A. Biodiversity certified land

The land is not biodiversity certified land under Part 8 of the *Biodiversity Conservation Act 2016* (includes land certified under Part 7AA of the repealed *Threatened Species Conservation Act 1995*).

10. Biodiversity Stewardship Sites

The Council has not been notified by the Chief Executive of the Office of Environment and Heritage that the land is a biodiversity stewardship site under a biodiversity stewardship agreement under Part 5 of the *Biodiversity Conservation Act 2016* (includes land to which a biobanking agreement under Part 7A of the repealed *Threatened Species Conservation Act 1995* relates).

10A. Native vegetation clearing set asides

Council has not been notified by Local Land Services of the existence of a set aside area under section 60ZC of the *Local Land Services Act 2013*.

11. Bush fire prone land

Bush Fire Prone Land

The land is not bush fire prone land.

Draft Northern Beaches Bush Fire Prone Land Map 2018

The land is not bush fire prone land.

12. Property vegetation plans

The Council has not been notified that the land is land to which a vegetation plan under the *Native Vegetation Act 2003* applies.

13. Orders under Trees (Disputes Between Neighbours) Act 2006

Council has not been notified of the existence of an order made under the *Trees (Disputes Between Neighbours) Act 2006* to carry out work in relation to a tree on the land.

14. Directions under Part 3A

There is not a direction by the Minister in force under section 75P(2) (c1) of the Act that a provision of an environmental planning instrument prohibiting or restricting the carrying out of a project or a stage of a project on the land under Part 4 of the Act does not have effect.

15. Site compatibility certificates and conditions for seniors housing

- (a) There is not a current site compatibility certificate (seniors housing), of which the council is aware, in respect of proposed development on the land.
- (b) No condition of consent applies to the property that limits the kind of people who may occupy the premises/ development. This refers only to consents granted after 11 October 2007 with conditions made in accordance with clause 18(2) of *State Environmental Planning Policy (Housing for Seniors or People with a Disability) 2004*.

16. Site compatibility certificates for infrastructure, schools or TAFE establishments

There is not a valid site compatibility certificate (infrastructure) or site compatibility certificate (schools or TAFE establishments), of which the council is aware, in respect of proposed development on the land.

17. Site compatibility certificate and conditions for affordable rental housing

- (a) There is not a current site compatibility certificate (affordable rental housing), of which the council is aware, in respect of proposed development on the land.
- (b) There are not terms of a kind referred to in clause 17 (1) or 38 (1) of *State Environmental Planning Policy (Affordable Rental Housing) 2009* that have been imposed as a condition of consent to a development application in respect of the land.

18. Paper subdivision information

There is no current paper subdivision, of which council is aware, in respect of this land according to Part 16C of the *Environmental Planning and Assessment Regulation 2000*.

19. Site verification certificates

There is no current site verification certificate, of which council is aware, in respect of the land according to Part 4AA of the *State Environmental Planning Policy (Mining, Petroleum Production and Extractive Industries) 2007*.

20. Loose-fill asbestos insulation

The residential dwelling erected on this land has not been identified in the Loose-Fill Asbestos Insulation Register as containing loose-fill asbestos ceiling insulation.

This clause applies to residential premises (within the meaning of Division 1A of part 8 of the Home Building Act 1989) that are listed in the register that is required to be maintained under that Division.

Contact NSW Fair Trading for more information.

21 Affected building notices and building product rectification orders

- (1) There is not an affected building notice of which the council is aware that is in force in respect of the land.
- (2) There is not a building product rectification order of which the council is aware that is in force in respect of the land and has not been fully complied with, and
- (3) There is not a notice of intention to make a building product rectification order of which the council is aware has been given in respect of the land and is outstanding.

In this clause:

affected building notice has the same meaning as in Part 4 of the *Building Products (Safety) Act 2017*.

building product rectification order has the same meaning as in the *Building Products (Safety) Act 2017*.

Additional matters under the Contaminated Land Management Act 1997

Note. The following matters are prescribed by section 59 (2) of the *Contaminated Land Management Act 1997* as additional matters to be specified in a planning certificate:

- (a) the land to which the certificate relates is not significantly contaminated land within the meaning of that Act
- (b) the land to which the certificate relates is not subject to a management order within the meaning of that Act
- (c) the land to which the certificate relates is not the subject of an approved voluntary management proposal within the meaning of that Act
- (d) the land to which the certificate relates is not subject to an ongoing maintenance order within the meaning of that Act
- (e) the land to which the certificate relates is not the subject of a site audit statement

If contamination is identified above please contact the Environmental Protection Authority (EPA) for further information.



Ray Brownlee PSM

Chief Executive Officer

01/06/2020